

fermacell

Flooring Systems

Planning and Installation

Version - February 2016



fermacell®

fermacell Flooring Elements – High quality dry floor constructions



Highly frequented areas



Living areas



Rooms in residential and office buildings,
studios



Museum and exhibition spaces



Corridors in residential and office buildings

fermacell

the ultimate building board

fermacell Gypsum Fibreboard was developed in 1971 and since then has become the obvious choice across Europe for high-performance dry lining projects.

Combining the strength of solid block work with the flexibility of dry lining, the acoustic, fire, moisture, impact and load hanging performance place fermacell in a category of its own, truly the "ultimate building board".

Made from recycled gypsum obtained as a waste product from coal fired power stations and recycled paper, **fermacell** Gypsum Fibreboard is completely recyclable making it an environmentally sound choice and improving BREEAM ratings.

Manufactured in 4 plants across Europe, **fermacell** Gypsum Fibreboard has for many years been associated with high performance dry-lining where its fire resistant (Euroclass A2), acoustic isolation and impact resistance are highly valued by construction industry professionals.

Subsequent product development has introduced the fermacell flooring system, made using the same base raw material – recycled gypsum and recycled paper fibers.

This dry flooring system is a practical and cost effective alternative to conventional wet screed to concrete floors, and because of its excellent thermal conductivity makes a great overlay to an under floor heating system.

Finally, its acoustic isolation properties are further enhanced with an optional wood fibre layer allowing excellent acoustic isolation between floors to be achieved.

With a European Technical Approval (ETA -03/0050) and associated CE mark fermacell flooring systems are independently certified at European level. In addition, fermacell flooring carries a BBA certificate (98/3358) giving an additional UK 3rd party accreditation to its performance.

Available nationally from specialist distributors and builders merchants, check our website www.fermacell.co.uk or call our office on 0121 311 3480 for your nearest stockist.





Table of contents

1. Introduction	6–9	3. Substrate and preparation	12–24	5. Flooring exposed to humidity	30–33
1.1 Simple advantages of using fermacell Flooring Elements	6	3.1 Substrate	12	5.1 Introduction	30–31
1.2 Quality with fermacell Flooring Elements	7	3.2 Installation conditions	14	5.2 Waterproofing Systems	32
2. Areas of application	8–11	3.3 Levelling	15–19	5.3 Installing the waterproofing system	33
2.1 Overview of areas of application	8–9	3.4 fermacell Honeycomb Acoustic Insulation System	20–21	6. Floor coverings	34–39
2.2 Area of application 1	10	3.5 Additional insulation materials	21	6.1 Installation Tolerance Guidelines	34
2.3 Area of application 2	10	3.6 Underfloor heating systems	22–24	6.2 Carpeting, PVC, cork and other coverings	35
2.4 Area of application 3	11	4. Installation	25–29	6.3 Ceramic tiles, natural stone paving and terracotta tiles	36–38
2.5 Area of application 4	11	4.1 Installation of fermacell Flooring Elements	25–27	6.4 Parquet, laminate	39
		4.2 fermacell greenline Floor Glue	28		
		4.3 Expansion/movement joints for fermacell Gypsum Fibreboard and Powerpanel H ₂ O Flooring Elements	29		

The content corresponds to the latest fermacell performance and installation instructions. Ensure that only the latest up to date documentation is used. Please note that the details and drawings are representative illustrated and should only be read in conjunction with the respective project drawings and specifications. Subject to Technical update and revision at any time.



7. Details	40–45	8. Specifications	46–47	10. Material requirements	60–62
7.1 Junction details (example illustrations)	40–43	8.1 fermacell Flooring Elements	46	10.1 Material usage tables	60–61
7.2 Doorway – Option 1: fermacell Flooring Elements T-jointed	44	8.2 fermacell Powerpanel H ₂ O Flooring Element	46	10.2 Installation times	62
7.3 Doorway – Option 2: Gypsum Fibreboard flooring installed lengthways	45	8.3 Structural specifications of fermacell Flooring Elements	47		
		8.4 Accessories	47		
		9. Building physics	48–59		
		9.1 Fire protection for flooring constructions	48–49		
		9.2 Sound insulation with fermacell flooring constructions	49–57		
		9.3 Sound insulation for Powerpanel H ₂ O Element flooring constructions	58		
		9.4 Testing and approval documents	59		

1.1 Simple advantages of using femacell Flooring Elements



- Manageable element-sizes - Easy to carry
- One-person installation
- Easy installation

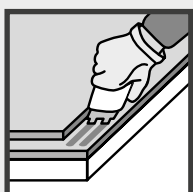
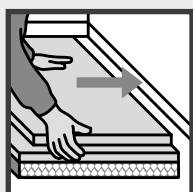

- Swift working process and installation
- Can be walked on almost immediately
- Chair castor roll resistance

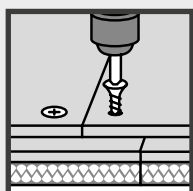

- Easy levelling
- Low additional weight to existing floor
- Simple and Effective complete system

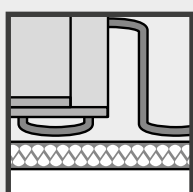

- Increased fire protection
- Improvement of sound insulation
- Effective heat insulation

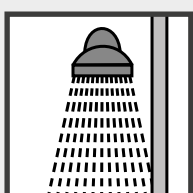
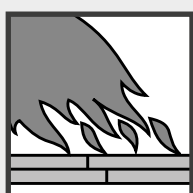

- Building biologically tested –
Ecological Benefits
- Suitable for domestic wet rooms



1.2 Quality Solutions with fermacell Flooring Elements



Durable and Sound insulating

Note:

Further information can be obtained from the fermacell sales and technical office - call 0121 311 3480 or go to www.fermacell.co.uk

1.2.1 System description

High quality floor constructions can be simply created with **fermacell** Flooring Elements. With regard to areas of use, they are comparable to conventional, solid flooring systems, however, they have the advantage of being lightweight as well as having a dry and fast installation (thus, no time-loss compared with wet screed floors).

fermacell Flooring Elements consist of two 10 mm or 12.5 mm thick **fermacell** boards glued together. The two boards are offset from one another, so that there is a 50 mm shiplap edge.

The element dimensions are 1500 x 500 mm (with 0.75 m² surface area/element).

fermacell Flooring Elements are available in a range of solutions as a floating floor system.

Practical advantage:

The Flooring Elements can be walked on once the glue has cured. Thus allowing floor finishes to be fitted almost immediately.

1.2.2 Choosing the right floor construction

When choosing the required fermacell floor construction, there are a number of influential boundary conditions and requirements:

- Type and properties of the existing floor and levelling required.
- Planned application area.
- Sound insulation requirements with regard to airborne and impact sound as well as and flanking sound reduction.
- Fire protection requirements.
- Thermal insulation requirements with the possibility of additional insulation.
- Moisture protection requirements (floorings and coverings must be matched to the level of humidity in domestic bathrooms and wet rooms).
- Required construction heights (pages 10-11).
- Aesthetic requirements, surface of the finished floor, integration of suitable underfloor heating systems, etc.

2 Areas of application

2.1 Overview of areas of application

The permissible load performance for **fermacell** Flooring Elements includes a safety factor of 2, which ensures a complete system construction with all appropriate floor coverings. The point loads can be used in conjunction with for all surface finishes, however, check the loading capability of the surface finish in its own right as well.

2.1.1 Areas of application

The flooring is a workable surface for a range of uses.

2.1.2 Scope of application

fermacell flooring offers solutions for a range of applications:

- New buildings
- Old-building renovation
- Living areas
- Office and administrative buildings
- Hospitals
- Lecture halls and classrooms
- Assembly rooms in public buildings
- Domestic wet rooms
- Floors in public showers
- Industrial flooring
- Useable floors in internal and external areas
- Dairies, breweries and swimming pools

Areas of Application to BS EN 1991-1-1:2002		Sub Category According to National Annex to BS EN 1991-1-1:2002	Point Load kN	Uniformly distributed or Live Load kN/m ²
No.				
Areas for domestic and residential activities		Category A		
1	Rooms in Residential Buildings and Houses (A1)*, Bedrooms and dormitories except those in self Contained single Family units and in Hotels and Motels (A2), Bedrooms in Hotels and Motels; Hospital Wards; Toilet Areas (A3)	A1/A2/A3	2,0	1.5/1.5/2.0
Office Areas		Category B		
2 to 3	General Use (B1), At or Below ground floor level (B2)	B1/B2	2,7	2.5/3.0
Areas where people may congregate		Category C		
3 to 4	Areas with Tables. Public, Institutional and communal Dining rooms and Lounges, Cafes and Restaurants (C11)*, and Reading Rooms with Book Storage (C12), and Classrooms (C13)	C1- Areas with Tables - C11/C12/C13	3.0/4.0/ 3.0	2.0/2.5/3.0
3 to 4	Assembly Areas with Fixed Seating (C21)*, Places of Worship (C22)	C2- Areas With Fixed Seats - C21/C22	3.6/2.7	4.0/3.0
4	Corridors, hallways, aisles in Institutional type Buildings NOT subjected to Crowds or Wheeled Vehicles, hostels, Guest Houses. Residential Clubs and Communal areas in Blocks of Flats (C31)*, Stairs and Landings (C32)*	C3 - Areas without obstacles for moving people - C31/C32	4.5/4.0	3,0
4	Corridors, Hallways, Aisles in ALL buildings not covered by C31 and C32, including Hotels, Motels and Institutional Buildings subjected to Crowds (C33), Stairs and Landings (C35)	C33	4.5/4.0	4.5/4.0
4	Corridors, Hallways, Aisles in ALL buildings not covered by C31 and C32, including Hotels, Motels and Institutional Buildings subjected to Wheeled Vehicles, including trolleys (C34)	C34	4,5	5,0
4	Museum Floors and Galleries for Exhibition Purposes (C39)	C39	4,5	4,0
4	Assembly Areas without fixed seating. Concert Halls, Bars and Places of Worship (C51)*	C5 - Areas Susceptible to Large Crowds - C51	3,6	5,0
Shopping Areas		Category D		
4	Areas in General Retail Shops (D1) and Department Stores (D2)	D1/D2	3,6	4,0

* See notes in National Annex for further details.

Areas of Application to BS 6399-1:1996		Category According to BS 6399-1:1996	Point Load kN	Uniformly distributed or Live Load kN/m ²	
No.					
Domestic and Residential Activity		Category A			
1	All usages within self-Contained Units Single Family Dwelling Units **. Communal Areas (including Kitchens) in Blocks of Flats with limited use.	A	1,4	1,5	
1	Bedrooms and Dormitories except those in single family dwelling units, and in Hotels and Motels.	A	1,8	1,5	
1	Bedrooms in Hotels and Motels; Hospital Wards; Toilet Areas.	A	1,8	2,0	
Offices and Work Areas not covered elsewhere		Category B			
4	Operating Theatres, X-ray rooms, Utility Rooms	B	4,5	2,0	
1 to 2	Work Rooms (Light Industrial) without storage	B	1,8	2,5	
2 to 3	Offices for General Use	B	2,7	2,5	
3	Banking Halls	B	2,7	3,0	
3 to 4	Kitchens, Laundries, Laboratories	B	4,5	3,0	
4	Machinery Halls, circulation spaces therein	B	4,5	3,5	
4	Factories, Workshops and Similar Buildings (general industrial)	B	4,5	5,0	
Areas where people may congregate		Category C			
2 to 3	Public, institutional and communal dining rooms and lounges, cafes and restaurants**	C1- Areas with Tables	2,7	2,0	
4	Reading Rooms with no Book Storage	C1	4,5	2,5	
3	Classrooms	C1	2,7	3,0	
4	Assembly Areas with Fixed seating**	C2- Areas With Fixed Seats	3,6	4,0	
3	Places of Worship	C2	2,7	3,0	
4	Corridors, hallways, aisles in Institutional type Buildings NOT subjected to Crowds or Wheeled Vehicles, hostels, Guest Houses. Residential Clubs and Communal areas in Blocks of Flats not covered by note 1 **	Corridors, hallways, aisles etc.. (foot traffic only)	C3 - Areas without obstacles for moving people	4,5	3,0
4		Stairs and Landings foot traffic only)	C3	4,0	3,0
4	Corridors, hallways, aisles, stairs landings etc.. in all other type Buildings including hotels and motel and Institutional buildings	Corridors, hallways, aisles etc.. (foot traffic only)	C3	4,5	4,0
4		Corridors, hallways, aisles etc.. subject to wheeled vehicles, trolleys etc..	C3	4,5	5,0
4		Stairs and Landings foot traffic only)	C3	4,0	4,0
4	Museum Floors and art galleries for Exhibition Purposes	C3	4,5	4,0	
4	Assembly areas without fixed seating, concert halls, bars, and places of worship**	C5 - Areas Susceptible to Overcrowding	3,6	5,0	
Shopping Areas		C5 - Areas Susceptible to Overcrowding			
4	Shop floors for the sales and display of merchandise	D	3,6	4,0	

** See notes in BS 6399-1 for further details.

2.1.3 Areas of application and permissible point load

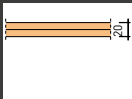
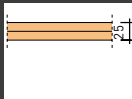
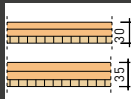
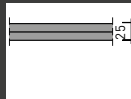
				
fermacell Flooring Element	2 E 11	2 E 22	2 E 31 (2 E 33)	Powerpanel H ₂ O Flooring Element
Construction	2 x 10 mm Gypsum Fibreboard	2 x 12,5 mm Gypsum Fibreboard	2 x 10 mm (2 x 12,5 mm) Gypsum Fibreboard + 10 mm Wood fibre	2 x 12,5 mm Powerpanel H ₂ O board
Area of application ***	1 + 2**	1 + 2 + 3**	1 + 2 + 3	1 + 2 + 3
Permissible point load	2,0 kN**	3,0 kN**	3,0 kN	3,0 kN
Increase of permissible point load with the addition 3 rd layer with 10 mm fermacell Gypsum Fibreboard*				
Area of application ***	1 + 2 + 3	1 + 2 + 3 + 4	1 + 2 + 3 + 4	
Permissible point load	3,0 kN	4,0 kN	4,0 kN	

* Installation of a 3rd layer **fermacell** Gypsum Fibreboard (page 27).
 ** If the non-laminated **fermacell** Flooring Elements are laid directly on the load-bearing subsurface, the permissible point load for 2 E 11 increases to 3.0 kN and to 4.0 kN for 2 E 22. Accordingly, the area of application extends to area 3 for 2 E 11 and area 4 for 2 E 22. The suitability for use of **fermacell** Flooring Elements was proven through tests at the Materials Testing Institute (MPA) Stuttgart.
 *** Refer to relevant performance table to either BS or EN performance requirements
 N.B. Factory of Safety for Loading = 2

2.1.4 Permissible point load

The allowable point load information refers to:

- A load area of at least 200 mm. (Stamp $\varnothing = 5$ mm).
- Particularly heavy objects, e.g. pianos, aquariums, bath tubs, must be taken into account separately in the planning and design.
- Where the point load spacing ≥ 500 mm, the allowable point loads can be added up over the whole surface area. In this case, the specified live loads may be exceeded.
- The sum of the point loads must not exceed the maximum permissible floor load capacity.
- Maximum deformation for the specified point loads at the floor edge is ≤ 3 mm.
- The point loads may only be applied at a distance of ≥ 250 mm from the flooring corner. If the distance is less, then a load dispersion pad of 100 mm diameter should be used.

2.2 Area of application 1

- For Example: Rooms in Residential Buildings and Houses, Bedrooms (except those in single family dwelling units) in Hotels, Motels and Hospital Wards.

Refer to Tables in Section 2.1.

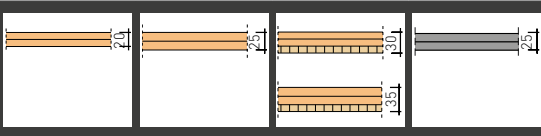

	2 E 11	2 E 22	2 E 31 (2 E 33)	Powerpanel H ₂ O Flooring Element
fermacell Flooring Element				
Construction	2 x 10 mm Gypsum Fibreboard	2 x 12,5 mm Gypsum Fibreboard	2 x 10 mm (2 x 12,5 mm) Gypsum Fibre- board + 10 mm Wood fibre	2 x 12,5 mm Powerpanel H ₂ O board
Additional levelling				
fermacell Bonded Levelling Compound	30 to 2 000 mm	30 to 2 000 mm	30 to 2 000 mm	30 to 2 000 mm
and/or				
fermacell Honeycomb system	30 or 60 mm	30 or 60 mm	30 or 60 mm	30 or 60 mm
and/or				
fermacell Levelling Compound ¹⁾	10 to 100 mm	10 to 100 mm	10 to 100 mm	10 to 100 mm
Additional height adjustment/additional insulation				
Polystyrene hard foam EPS DEO 100 kPa ²⁾	max. 30 mm	max. 30 mm	-	max. 30 mm
alternative				
Polystyrene hard foam EPS DEO 150 kPa ²⁾	max. 70 mm	max. 90 mm	max. 60 mm	max. 90 mm
alternative				
Polystyrene hard foam EPS DEO 200 kPa ²⁾	max. 100 mm	max. 120 mm	max. 90 mm	max. 120 mm
alternative				
Extruded hard foam XPS DEO 300 kPa max. in 2 layers	max. 100 mm	max. 120 mm	max. 90 mm	max. 120 mm
alternative				
Extruded hard foam XPS DEO 500 kPa max. in 2 layers	max. 140 mm	max. 160 mm	max. 150 mm	max. 160 mm

¹⁾ This is a simple dry fill application with no further binding agents, thus a compaction of up to 5 % should be allowed for. Note: In order to improve sound insulation, in particular for wooden joist floors, mineral wool or wood fibre boards are more suitable than hard foam insulation boards.

fermacell Flooring Elements 2 E 22 (25 mm) are particularly well suited as an overlay for hot water underfloor heating [page 22].

²⁾ Compressive strength [kPa] at 10 % compression to DIN EN 13163 - check relevant BS EN standard for comparison if required.

2.3 Area of application 2

- For Example: General Use. Public, Institutional and communal dining rooms, lounges, cafes and restaurants.

Refer to Tables in Section 2.1.

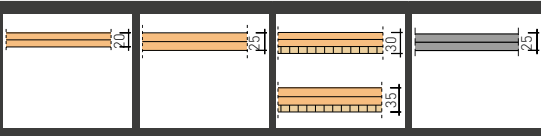

	2 E 11	2 E 22	2 E 31 (2 E 33)	Powerpanel H ₂ O Flooring Element
fermacell Flooring Element				
Construction	2 x 10 mm Gypsum Fibreboard	2 x 12,5 mm Gypsum Fibreboard	2 x 10 mm (2 x 12,5 mm) Gypsum Fibre- board + 10 mm Wood fibre	2 x 12,5 mm Powerpanel H ₂ O board
Additional levelling				
fermacell Bonded Levelling Compound	30 to 2 000 mm	30 to 2 000 mm	30 to 2 000 mm	30 to 2 000 mm
and/or				
fermacell Honeycomb system	30 or 60 mm	30 or 60 mm	30 or 60 mm	30 or 60 mm
and/or				
fermacell Levelling Compound ¹⁾	10 to 60 mm	10 to 60 mm	10 to 60 mm	10 to 60 mm
Additional height adjustment/additional insulation				
Polystyrene hard foam EPS DEO 100 kPa ²⁾	max. 30 mm	max. 30 mm	-	max. 30 mm
alternative				
Polystyrene hard foam EPS DEO 150 kPa ²⁾	max. 70 mm	max. 90 mm	max. 60 mm	max. 90 mm
alternative				
Polystyrene hard foam EPS DEO 200 kPa ²⁾	max. 100 mm	max. 120 mm	max. 90 mm	max. 120 mm
alternative				
Extruded hard foam XPS DEO 300 kPa max. in 2 layers	max. 100 mm	max. 120 mm	max. 90 mm	max. 120 mm
alternative				
Extruded hard foam XPS DEO 500 kPa max. in 2 layers	max. 130 mm	max. 160 mm	max. 130 mm	max. 160 mm

* Unsuitable

¹⁾ This is a simple dry fill application with no further binding agents, thus a compaction of up to 5 % should be allowed for. Note: **fermacell** Flooring Elements 2 E 22 (25 mm) are particularly well suited as an overlay for hot water underfloor heating [page 22].

²⁾ Compressive strength [kPa] at 10 % compression to DIN EN 13163 - check relevant BS EN standard for comparison if required.

2.4 Area of application 3

- For Example: kitchens in hotels and retirement homes without heavy machinery, Classrooms; Treatment rooms in hospitals.
Refer to Tables in Section 2.1.

- Areas with tables; e.g. classrooms, cafes, restaurants, dining rooms, lecture halls, reception rooms, crèches, day nurseries, staff rooms.

Refer to Tables in Section 2.1.

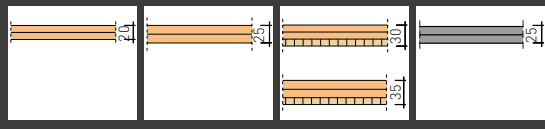

	2 E 11	2 E 22	2 E 31 (2 E 33)	Powerpanel H ₂ O Flooring Element
fermacell Flooring Element				
Construction	2 x 10 mm Gypsum Fibreboard	2 x 12,5 mm Gypsum Fibreboard	2 x 10 mm (2 x 12,5 mm) Gypsum Fibre- board + 10 mm Wood fibre	2 x 12,5 mm Powerpanel H ₂ O board
10 mm fermacell Gypsum Fibreboard**	+ 3 rd layer			
Additional levelling				
fermacell Bonded Levelling Compound	30 to 2 000 mm	30 to 2 000 mm	30 to 2 000 mm	30 to 2 000 mm
and/or				
fermacell Honeycomb system	30 or 60 mm	30 or 60 mm	30 or 60 mm	30 or 60 mm
and/or				
fermacell Levelling Compound ¹⁾	10 to 60 mm	10 to 60 mm	10 to 60 mm	10 to 60 mm
Additional height adjustment/additional insulation				
Polystyrene hard foam EPS DEO 100 kPa ²⁾	-	-	-	-
alternative				
Polystyrene hard foam EPS DEO 150 kPa ²⁾	max. 70 mm	max. 70 mm	max. 40 mm	max. 70 mm
alternative				
Polystyrene hard foam EPS DEO 200 kPa ²⁾	max. 100 mm	max. 100 mm	max. 70 mm	max. 100 mm
alternative				
Extruded hard foam XPS DEO 300 kPa max. in 2 layers	max. 100 mm	max. 100 mm	max. 70 mm	max. 100 mm
alternative				
Extruded hard foam XPS DEO 500 kPa max. in 2 layers	max. 140 mm	max. 140 mm	max. 110 mm	max. 140 mm

* Unsuitable

** Point load increased by installation of a 3rd layer **fermacell** Gypsum Fibreboard 10 mm (page 27).

¹⁾ This is a simple dry fill application with no further binding agents, thus a compaction of up to 5 % should be allowed for.

²⁾ Compressive strength [kPa] at 10 % compression to DIN EN 13163 - check relevant BS EN standard for comparison if required.

2.5 Area of application 4

- For Example: Corridors in hospitals (in deviation from BS EN 1991-1-1:2002) and all examples from B1 and B2, but with heavy machinery
- Areas in churches, theatres or cinemas, conference rooms, lecture rooms, waiting rooms
- Areas in specialist shops and warehouses.

Refer to Tables in Section 2.1 for specific loading allowances

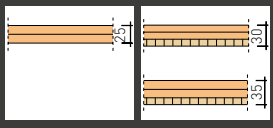

	2 E 22	2 E 31 (2 E 33)
fermacell Flooring Element		
Construction	2 x 12,5 mm Gypsum Fibreboard	2 x 10 mm (2 x 12,5 mm) Gypsum Fibre- board + 10 mm Wood fibre
10 mm fermacell Gypsum Fibreboard**	+ 3 rd layer	+ 3 rd layer
Additional levelling		
fermacell Bonded Levelling Compound	30 to 2 000 mm	30 to 2 000 mm
and/or		
fermacell Honeycomb system	30 or 60 mm	30 or 60 mm
and/or		
fermacell Levelling Compound ¹⁾	10 to 60 mm	10 to 60 mm
Additional height adjustment/additional insulation		
Polystyrene hard foam EPS DEO 100 kPa ²⁾	-	-
alternative		
Polystyrene hard foam EPS DEO 150 kPa ²⁾	max. 70 mm	max. 40 mm
alternative		
Polystyrene hard foam EPS DEO 200 kPa ²⁾	max. 100 mm	max. 70 mm
alternative		
Extruded hard foam XPS DEO 300 kPa max. in 2 layers	max. 100 mm	max. 70 mm
alternative		
Extruded hard foam XPS DEO 500 kPa max. in 2 layers	max. 140 mm	max. 110 mm

* Unsuitable

** Point load increased by installation of a 3rd layer **fermacell** Gypsum Fibreboard 10 mm (page 27).

¹⁾ This is a simple dry fill application with no further binding agents, thus a compaction of up to 5 % should be allowed for.

²⁾ Compressive strength [kPa] at 10 % compression to DIN EN 13163 - check relevant BS EN standard for comparison if required..

3 Substrate and preparation

3.1 Substrate

fermacell Flooring Elements can be installed on a number of substrates. These must be fully supportive as the main structural element. fermacell flooring is not a spanable structural element.

3.1.1 Solid floor

If the floor component contains residual moisture (core moisture), then a protective DPC should be laid first. Typically this will be a 0.2 mm polyethylene sheet. All joints should be overlapped by a minimum of 200 mm and taped and sealed (refer to DPC manufacturers guidelines).

At the perimeter of the room the DPC sheet should be turned up to the height of the finished floor level.

3.1.2 Solid floors over ground

Floor components bordering soil must have additional permanent protection incorporated against increased humidity for the floor and wall area. Refer to the relevant British Standard for moisture protection in these areas.

3.1.3 Timber joist floor with structural floor deck

Timber joists are overlaid with a spanable floor deck such as 22 mm Chipboard or a similar suitable material. In renovation projects the condition of the existing floor must be checked prior to the installation of any **fermacell** Flooring Elements. Any necessary repairs should be carried out. The floor should not be springy or deflect significantly. Where required, and to ensure a full surface support, refer to section 3.3 on levelling (refer to manufacturers recommendations).

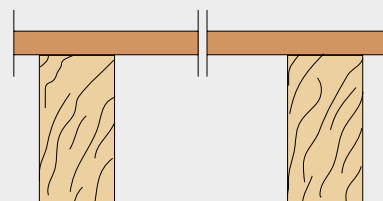
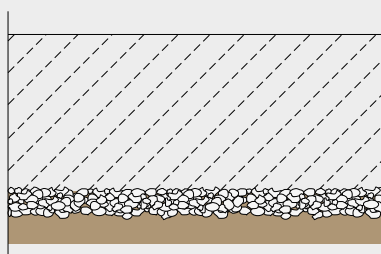
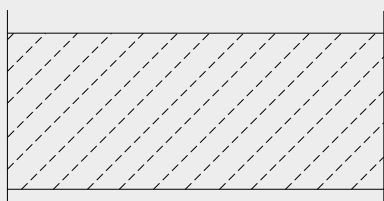

TIP:

A full area support and a stable, dry **substrate** are required for the installation of fermacell Flooring Elements.

3.1.4 Timber joist floor with a recessed floor deck

Where ceiling heights are restrictive, then a recessed floor deck to match into the top of the joists can be used. This allows for the installation of the fermacell Flooring Elements with a reduced overall build height.

Lower level recessed floor deck sections can be filled with **fermacell** Bonded Levelling Compound, see details in section 7.1.3. Please refer to the allowable construction infill depths (see pages 10 and 11). Ensure that the load-bearing capacity of any recessed decking detail is structurally checked by a qualified engineer.

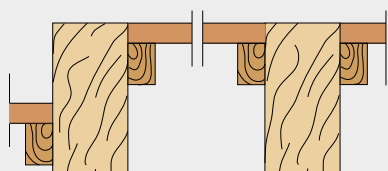

3.1.5 Trapezoidal steel sheet floors

To give a full contact support area for **fermacell** Flooring Elements lay a load-bearing timber sheeting layer directly on to the trapezoidal steel sheet.

Where specified for fire protection requirements, an additional layer of **fermacell** Gypsum Fibreboard or Powerpanel H₂O boards should be laid directly over the trapezoidal steel sheet floor.

Alternatively, smaller void depths up to 50 mm can also be created using **fermacell** Levelling Compound; minimum void depth 10 mm.

Void depths of minimum 40 mm can be filled with **fermacell** Bonded Levelling Compound.



3.1.6 Steel beam floors

The steel beams and associated structural layer must be designed by a qualified engineer. The structural deck of the floor may be either timber-based boards, plywood sheets, structural cements boards, or similar. Refer to Structural Engineers calculations.

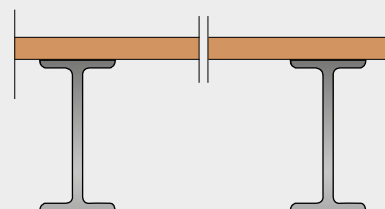

3.2 Installation conditions

3.2.1 Construction site storage

fermacell Flooring Elements are delivered on pallets and are protected against moisture and contamination by special packaging.

fermacell Flooring Elements must be stored flat on a structurally sound, level base and protected against moisture and rain.

Storing of gypsum fibre boards and Powerpanel H₂O Flooring Elements upright on their edges can lead to deformation in the boards.

3.2.2 General installation conditions

- I. **fermacell** Flooring Elements must not be installed at a mean relative humidity above 70 %.
- II. The jointing of **fermacell** Flooring Elements should take place at a relative humidity \leq 70 % and a room temperature \geq +5 °C. In this respect, the glue temperature should be \geq +15 °C. The flooring elements must have been acclimatised to the internal climate. After jointing, this indoor environment must not change significantly for at least 24 hours.

- III. Levelling compounds and flooring elements must only be installed once any plastering works are complete and dry.
- IV. The use of gas burner heating can lead to damage due to the build-up of moisture and thermal shock, and should be clearly avoided. This applies in particular for cold interiors with poor ventilation.
- V. The climatic conditions in the installation area must not change significantly 24 hours before, during and 24 hours after the installation.

Concrete or Solid floors

Any irregularities should be repaired or removed, the entire surface cleaned in preparation. A polyethylene sheet of 0.2mm thickness, or similar, should be spread over the entire surface., ensuring a minimum 200mm overlap between sheets. These joints should be taped to give a suitable seal.

Timber joist floors

When using on timber joist floors, trickling out of the levelling compound through cracks and knotholes can be prevented by using the **fermacell** Trickle Protection Sheet. See page 16 for further details. Ensure any loose floorboards are securely fixed down first.

3.3 Levelling

3.3.1 Preparation of bare floor: Level/Flatness of the existing floor

A level subsurface is required for the installation of **fermacell** Flooring Elements. The **fermacell** levelling options are:

- from 0 to 20 mm with **fermacell** Self-Levelling Compound,
- from 10 to 60 (100) mm with **fermacell** Dry Levelling Compound,
- from 30 to 2 000 mm with **fermacell** Bonded Levelling Compound.

3.3.2 **fermacell** Self-Levelling Compound

The **fermacell** Self-Levelling Compound is the ideal solution for levelling off unevenness of up to 20 mm height in flooring.

Areas of use:

fermacell Self-Levelling Compound is suitable as a surface finish:

- for load-bearing, dry and dust-free substrates made of **fermacell** Flooring Elements, concrete, anhydrite or chipboard for internal areas
- on T & G boarding exclusively for the installation of flooring elements
- as a substrate under floor coverings, e.g. textile, PCV, etc., see section 6 floor coverings.
- May be placed above or below **fermacell** Flooring Elements.

Preparation of the substrate

Defects and damage to the substrate, e.g. holes, cracks or protruding joints must be levelled off with fermacell joint filler. The subsurface must be load-bearing, clean, permanently dry and free from any separating agents, dust, oils and substances that could affect adhesion. Loose substrates must be fixed down or repaired. Loose coatings must be removed.

The self-levelling compound must not be applied to plastic or waterproofing sheeting.

In order to ensure the necessary adhesion and to facilitate installation, the substrate should be treated with a primer/sealer, e.g. with **fermacell** Deep Primer. Where the **fermacell** Flooring Elements have been sanded, the primer/sealer must be reapplied after the first coating has dried.

When applying to **fermacell** Flooring Elements, ensure that any protruding perimeter strips are cut off level after fitting the **fermacell** Flooring Elements.

Mixing

fermacell Self-Levelling Compound is supplied in 25 kg bags. 1 bag = approx. 15 m² at 1 mm thickness. Approx. 6.5 l cold, clear water is required per bag. The fermacell self-levelling compound is added to the water whilst mixing vigorously. Working Time = Maximum 30 minutes.

Installation

In a single application apply the pre-mixed levelling compound to the desired layer thickness and level out (as required, with a trowel or spiked roller). For layer thicknesses up to 3 mm, the surface can be walked on after 3 hours and it will be ready for covering after 24 hours (based on an internal temperature of 20 °C and max. 65 % relative humidity). For multiple layers of fermacell self-levelling, the lower layer must be completely dry and a subsequent layer of **fermacell** Deep Primer must be applied between layers as an intermediate primer.

Note: Protect against draught!



Preparation: Prime floor



Mix in clean container:
6.5 l water/ 25 kg bag



Mix with a suitable mixer at a low speed, until a homogenous, lump-free levelling compound is created



Pour out self-levelling compound and level off



Fitting the perimeter strips



Preparing the area to be levelled

3.3.3 **fermacell** **Levelling Compound**

The **fermacell** Levelling Compound is a special dried, mineral aerated concrete granulate, whose particular structural-physical properties make it very versatile.

The material locks itself together due to the angular grain shape, thus providing excellent stability.

As it is a mineral compound, with no additional binders, a possible compaction of approx. 5 % may occur and thus must be taken into account.

Areas of use

fermacell Levelling Compound is used for levelling uneven floors in old and new buildings.

It is especially suitable for lightweight floor constructions (timber joist floor), as it reduces additional structural loading to the building.

Preparation

When using on timber joist floors, trickling out of the levelling compound through cracks and knotholes can be prevented by using the **fermacell** Trickle Protection Sheet.

The trickle protection sheet must be turned up the corners and wall perimeters to sit above the final floor finish level. When using a PE sheet as trickle protection, ensure that it is suitable for the structural-physical conditions of use.

Installation

The finished floor level of the dry flooring must be set out and marked on the walls with the aid of a level, chalk line and/or a laser. Then fit the perimeter strips.

Easy to lay

Approx. 200 mm wide haunches/dams of **fermacell** Levelling Compound are laid to each side of the area to be levelled. The edge rails are then levelled out, and then the **fermacell** Levelling Compound is poured out and then scraped flush to the required level.

The dry levelling compound does not require any further compaction.

Apply levelling compound

The **fermacell** Levelling Compound is applied between the haunches/dams and scraped to the correct level with the **fermacell** floor leveller. Laying of **fermacell** Flooring Elements or additional layers can then begin.

Maximum Depth for **fermacell** Dry Levelling Compound:

1. Domestic Use – 100 mm.
2. Other Areas – 60 mm

N.B. Allow for compaction of up to 5 % when covered.

Load-distributing board

In the following applications a load-distributing board must be laid on top of the **fermacell** Levelling Compound before laying any other flooring. e.g., dry butted 10 mm thick **fermacell** Gypsum Fibreboard.

- Use of **fermacell** Flooring Elements 2 E 32 and 2 E 35 over 60 mm dry levelling compound.
- For use with a hot water underfloor heating system (see section 3.6.6.

Notes

- As an alternative to the **fermacell** Floor Levelling Set use a suitable timber straight edge as guide rails.
- The levelling rail should have notches at the ends.
- A spirit level should be used for levelling.
- The timber straight edge must not be left in the levelling compound.
- Service pipes must be covered with a min. 10 mm layer of dry levelling compound.



Apply **fermacell** Levelling Compound



Place **fermacell** Flooring Element on to **fermacell** Levelling Compound



- Minimum thickness of dry levelling compound to be used is 10 mm.
- To avoid condensation issues, ensure the area is correctly prepared and sealed.
- When fitting installation pipes, ensure corrosion, heat, sound and fire protection is not affected.

TIP:

The **fermacell** Levelling Compound must not be walked-on. The installation sequence should start to allow fitting towards the door. When placing the flooring elements, intermediate stepping stone step boards should be used, e.g. **fermacell** board offcuts > 500 x 500 mm.

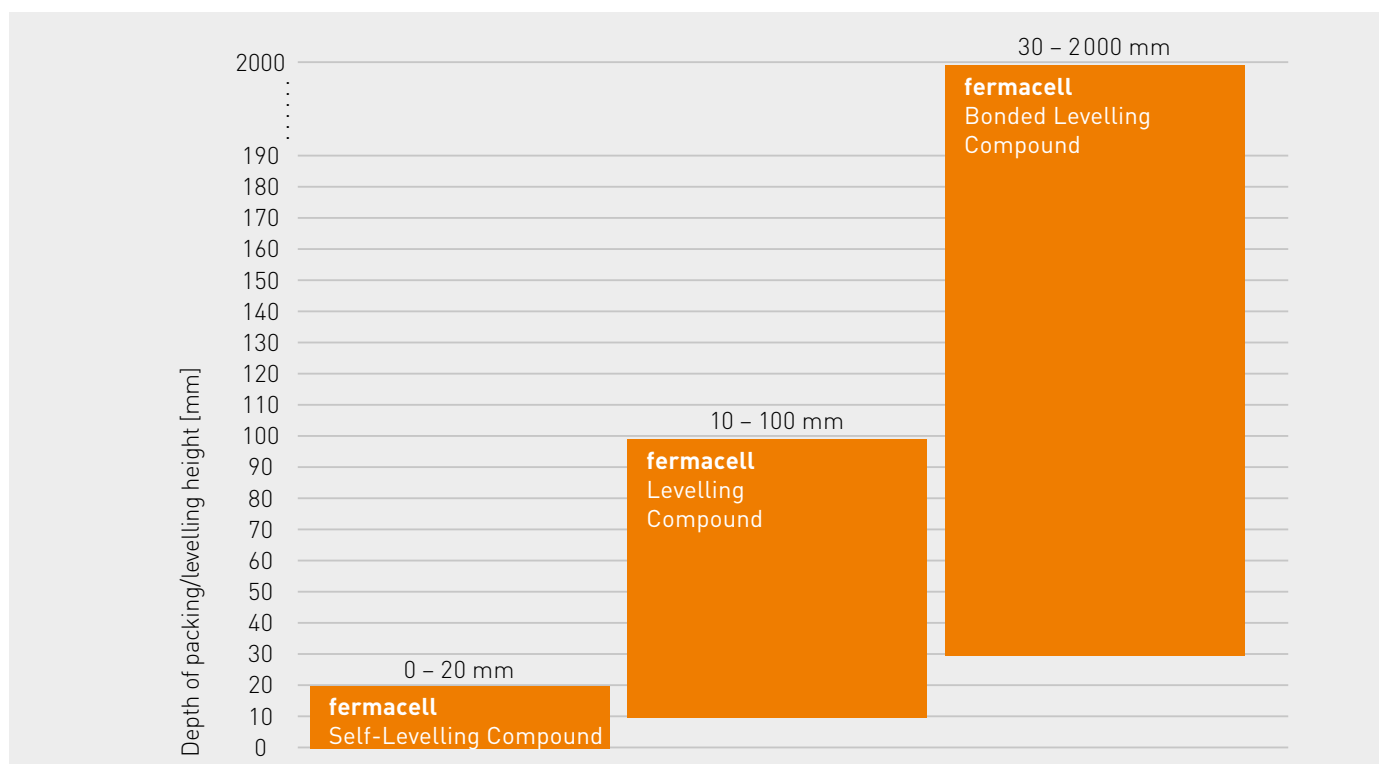



1 Thoroughly mix the entire contents of the bag in a suitable mixer ...



2 ... with approx. 8 –10 litres of water



3 The bonded levelling is then laid out as required



4 The first levelling edge is laid out and aligned

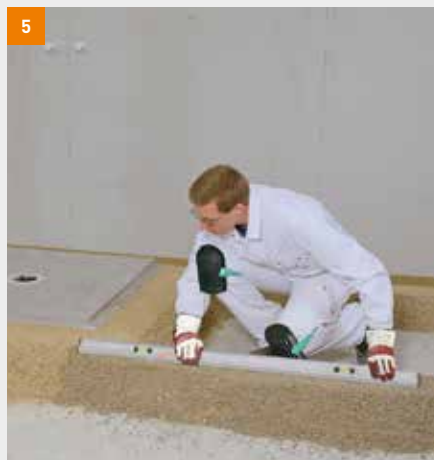

5 The second levelling edge is then laid out and aligned

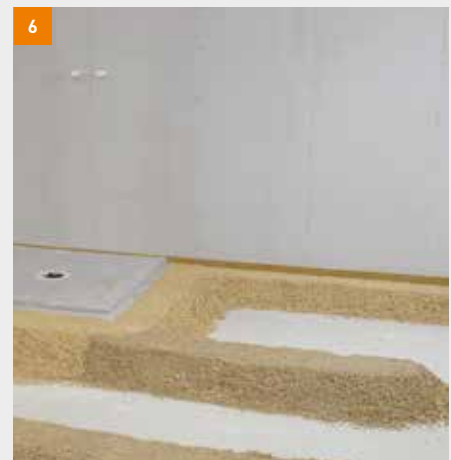

6 Wait until the levelling edges are dry (approx. 20 minutes)

3.3.4 fermacell Bonded Levelling Compound

fermacell Bonded Levelling Compound is a recycled foam insulation with a grain size of 2 to 8 mm mixed with a cement-based binding agent.

- The foam insulation has a low weight and good thermal insulation.
- The cement-based binding agent gives high stability and prevents the levelling compound from settling. It creates a stable surface, which can be walked-on after approx. 6 hours.

The bonded levelling compound is an ideal addition to the **fermacell** flooring range as it gives a solution for heights of up to 2 m.

Areas of use

- Under **fermacell** Flooring Elements and Powerpanel H₂O Flooring Element
- For wet rooms.
- On supported solid, wooden joist, trapezoidal steel sheet floors, vaulted ceilings, etc.
- In living areas, public buildings, schools, etc.
- Areas with greater load requirements
- May be used under other flooring systems

Area Preparation

Firstly determine the finished level of the dry flooring and mark this on the surrounding walls with a suitable levelling tool. The subsurface must be

load-bearing, clean, permanently dry and free from any separating agents and substances that could affect adhesion. Loose substrates must be fixed down and any loose coatings must be removed.

In order to ensure the necessary adhesion, the subsurface must be treated with a primer, e.g. **fermacell** Primer. A separating layer, e.g. trickle protection or DPM, should be avoided.

As required, then, fit perimeter strips. These must completely decouple the flooring construction (incl. floor covering) from the surrounding walls.



Fill in between the levelled edges and level out.



Mixing

The entire contents of the bag must be mixed with approx. 8-10 litres of water, until it is thoroughly mixed and lump free.

Installation

An approx. 200 mm wide levelling edge is created to each side of the area to be levelled. These are built to the required level and allowed to dry. Once the edge sections are dry, then the middle can be completed in the same way. This can be levelled off using a **fermacell** Levelling Set or a suitable set of straight edges. Any unevenness can be trowelled smooth. **fermacell** Bonded Levelling Compound can be walked-on after approx. 6 hours and is ready for over-laying after 24 hours (at 20 °C and at max. 65 % relative humidity).

Walking routes on the compound must be covered and protected. It should be noted that **fermacell** Bonded Levelling Compound is not a final walking surface. Tools and mixers must be cleaned thoroughly with water after use.

The finished surface must be protected from draughts during the setting process!

Notes

- Minimum depth of material = 30 mm.
- Suitable for depths from 30 mm to 2000 mm in layers up to 500 mm at a time.
- Beams, steel sections, etc. can be used on the top level as an alternative (see Details).
- General installation precautions should be taken to avoid condensation.

- When fitting installation pipes, ensure corrosion, heat, sound and fire protection is not affected.
- The **fermacell** Bonded Levelling Compound is not a final walking surface. Floor coverings must not be directly applied.
- Fine adjustment can be achieved using **fermacell** Self-Levelling Compound.

Note:
For typical constructions please see page 43



fermacell Honeycomb Acoustic Insulation System



Lay **fermacell** Honeycomb System



Apply **fermacell** Honeycomb Infill

3.4 fermacell Honeycomb Acoustic Insulation System

Areas of use

The **fermacell** Honeycomb System is suitable for both new build and renovation or refurbishment projects.

- The honeycomb system is used in conjunction with the 30 mm **fermacell** acoustic flooring.
- Overall this 60 or 90 mm high floor construction gives an additional surface weight of approx. 70 or 115 kg/m².
- Impact sound improvement of up to up to 34 dB can be achieved, depending on the construction.

Installation

fermacell Honeycomb Flooring is laid over full floor. Additional paper strips are used to overlap the sheets on the long edge. Paper strips need only be applied on the front sides as trickle protection when there is a risk that the honeycomb infill could trickle away through knotholes or cracks.

Apply honeycomb infill

Fill the honeycomb with the **fermacell** Honeycomb Infill.

Start filling away from the door and tread carefully on the filled honeycomb. Level out the **fermacell** Honeycomb Infill into the honeycomb with a straight-edge or brush, to leave a level substrate.

Use an electric hammer drill or similar tool with vibration function to compact the 60 mm high honeycomb infill. The 30 mm high honeycomb infill should not be compacted.

fermacell Flooring Elements

For acoustic performance, the following **fermacell** Flooring Elements can be laid on top of the **fermacell** Honeycomb Infill:

- 2 E 31 (2 x 10 mm Gypsum Fibreboards + 10 mm wood fibre).
- 2 E 33 (2 x 12.5 mm Gypsum Fibreboards + 10 mm wood fibre).



Level out **fermacell** Honeycomb Infill



Lay **fermacell** Flooring Elements

Notes

- The increased mass of the system onto the structural floor (approx. 45 or 90 kg/m².) significantly reduces the transmission of sound.
- Installation pipes can be cut in to the system, up to 100 mm wide in the **fermacell** Honeycomb Flooring (this may affect the sound and fire protection properties).
- The **fermacell** Honeycomb Flooring can be over filled to max. of 3 mm, with **fermacell** Honeycomb Infill.
- A further height adjustment above the **fermacell** Honeycomb Flooring can be achieved with **fermacell** Dry Levelling Compound (see section 3.3.3, **fermacell** Dry Levelling Compound).

Further insulation and other materials can be used to build up and increase the height of **fermacell** flooring systems.

An even, load-bearing substrate is necessary for laying these insulation boards.

It should be noted that the traffic and point load capability of the **fermacell** Flooring Element may change if alternative insulation materials are used.

The use of hard foam boards, e.g. polystyrene, on wooden joist floors is not recommended for sound insulation reasons. Pressure-resistant wood fibre or high density mineral wool insulation boards are better suited for these types of floors.

Where using mineral wool acoustic insulation boards with **fermacell** Levelling Compound, a 10 mm thick **fermacell** Gypsum Fibreboard is required between the **fermacell** Levelling Compound and the mineral wool insulation boards as a load distribution board (see Detail).

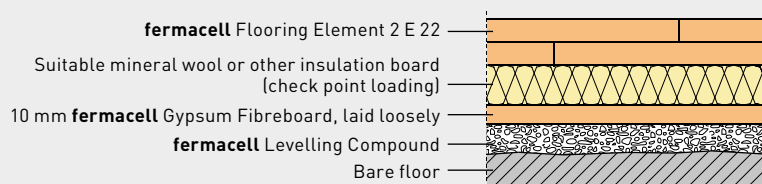

Detail: Suitable mineral wool insulation boards on **fermacell** Levelling Compound with a dry butted **fermacell** Gypsum Fibreboard, laid as a load distribution board.

3.5 Additional insulation materials

3.6 Underfloor heating systems

3.6.1 fermacell Flooring Elements over underfloor heating systems

For warm water under-floor heating systems, the 25 mm 2 E 22 or 20 mm 2 E 11 **fermacell** (only for specific systems) Flooring Elements are the ideal solution; providing the fast response times not possible with concrete screeds, coupled with the rapid installation of a dry flooring system. Further detailed information is available in the document "**fermacell** Dry Flooring Elements – Instruction Manual".

3.6.2 Areas of use

The underfloor heating manufacturer must be consulted with regard to use in areas with high load requirements.

3.6.3 Hot water underfloor heating systems

Hot water underfloor heating systems for dry flooring typically consist of heating pipes in special moulded boards, e.g. moulded polystyrene boards or routed wood fibre insulation

boards (see example 2). The heat is distributed by special heat conducting plates. The Flooring Elements lay over the heat conducting plates.

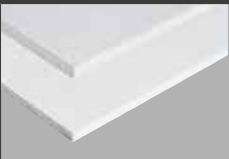
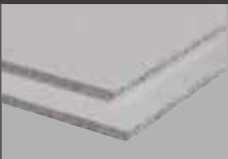
	Flooring Element 2 E 22	Powerpanel H ₂ O Flooring Element
		
Description	2 x 12.5 mm Gypsum Fibreboard	2 x 12.5 mm Powerpanel H ₂ O board
Thickness (mm)	25	25
Size (mm)	500 x 1500	500 x 1250
Weight (kN/m ²)	0.29	0.25
Thermal resistance (m ² k/W)	0.08	0.14
Application recommendations	<ul style="list-style-type: none"> - Hot water underfloor heating - Domestic wet rooms - Inlet temperatures max. 55 °C 	<ul style="list-style-type: none"> - Hot water or electric underfloor heating - Wet rooms - No limitation of inlet temperatures

The **fermacell** Flooring Elements shown in the table can be used on the following installed underfloor heating systems.



Another hot water heating system is the so-called climate-controlled floor. This system consists of heating media-conducting boards, e.g. made of routed **fermacell** Gypsum Fibreboards (see example 1).

An inlet temperature of 55 °C must not be exceeded for **fermacell** Flooring Elements!

There is no limitation of inlet temperature for the **fermacell** Powerpanel H₂O Flooring Elements due to its material properties.

3.6.4. Electric underfloor heating systems

Electrically powered heating systems, e.g. thin-bed heating mats, are generally installed directly underneath the floor covering. They primarily serve as additional heating or floor tempering.

The Powerpanel H₂O Flooring Elements are very well suited for electrical underfloor heating systems due to their material properties.

Electric underfloor heating systems are only suitable for use with **fermacell** Flooring Elements after consultation with the floor heating system manufacturer. Heat accumulation (hot spots) due to the covering of the heating surface, e.g. by furniture or other heat insulating layers (e.g. thick carpets, textiles, etc..) must be avoided at all times. The maximum temperature must not exceed 50 °C at any point on the flooring elements!

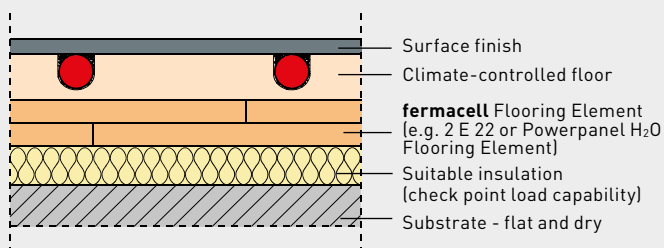

Example 1:
Climate-controlled floor on **fermacell** Flooring Element 2 E 22 or Powerpanel H₂O Flooring Element

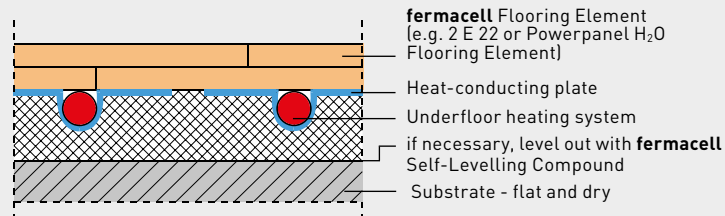

Example 2:
fermacell Flooring Element 2 E 22 or Powerpanel H₂O Flooring Element on hot water underfloor heating

3.6.5 Installation guidelines

If for structural reasons, additional insulation material is required underneath the underfloor heating system, it must be a flooring grade type and suitable for use in these areas.

If underfloor heating systems are being used with **fermacell** Levelling Compound, a loosely laid 10 mm **fermacell** Gypsum Fibreboard must be placed as a load-distributing board (joint offset min. 400 mm) between the levelling compound and the moulded underfloor heating system board (see Detail 1).

When using approved mineral wool insulation boards underneath the underfloor heating, a 10 mm **fermacell** Gypsum Fibreboard must be placed as a load-distributing board (joint offset min. 400 mm) between the mineral wool insulation board and the moulded underfloor heating system board (see Detail 2).

For larger cavities, such as pipe assemblies in the heating circuit area, additional supporting measures are required, e.g. the installation of sheet metal, due to the greater voids under the contact surfaces. For further details contact the underfloor heating manufacturer.

Heat-conducting plates or heating elements must not be bent, so that the flooring elements can lay flat.

Before installing flooring elements, it is recommended to add a separating layer (e.g. DPM or similar min. 0.2 mm or kraft paper) on the moulded underfloor heating boards, to prevent the flooring elements from sticking to the underfloor heating system.

3.6.6 Additional insulation layers

Additional insulation materials underneath suitable underfloor heating are specified in the table below. The thicknesses, incl. moulded underfloor heating system board, must be observed.

Differing insulation material and insulation thicknesses may be used, however, check with the **fermacell** technical department.

	Flooring element 2 E 22	Powerpanel H ₂ O Flooring Element
Additional insulation material in area of application 1		
<ul style="list-style-type: none"> - Thickness incl. moulded underfloor heating board - Install insulation material in single layer 	<ul style="list-style-type: none"> - max. 90 mm polystyrene hard foam insulation (EPS DEO 150) or - max. 120 mm extruded hard foam insulation (XPS DEO 300) 	<ul style="list-style-type: none"> - max. 90 mm polystyrene hard foam hard (EPS DEO 150) or - max. 120 mm extruded hard foam hard (XPS DEO 300)

3.6.7 Underfloor heating details

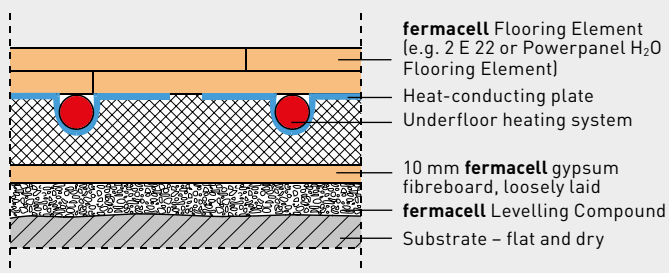

Detail 1: Underfloor heating system on **fermacell** Levelling Compound, with a **fermacell** Gypsum Fibreboard load distribution board

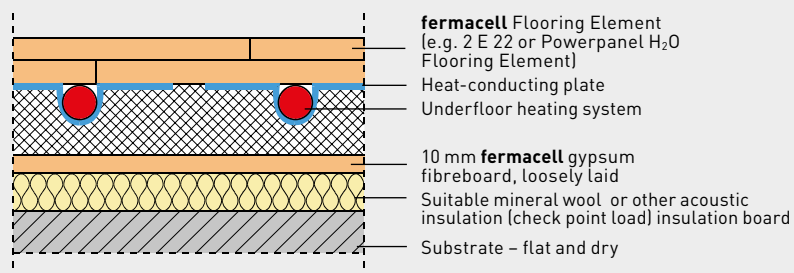

Detail 2: Underfloor heating system on additional mineral wool insulation board, with a **fermacell** Gypsum Fibreboard load distribution board

When installing the latest fitting installation guidelines from Fermacell GmbH and the corresponding underfloor heating manufacturer as well as applicable national guidelines and rules must be observed!

4 Installation

4.1 Installation of fermacell Flooring Elements

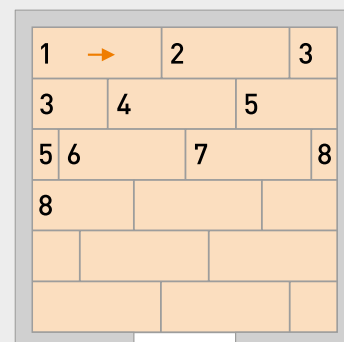

Installation diagram 1 – installation towards the door opening

4.1.1 Preparation

fermacell Flooring Elements are easy to install. Ensure that the floor is clean, dry and even, so that the fermacell flooring rests on the entire surface. The board laps are glued and fixed together (screwed or stapled).

Perimeter strips

All adjoining components (e.g. walls, supports, heating pipes) must be decoupled from the flooring construction (incl. floor coverings!) by **fermacell** Perimeter Strips.

Ensure that the perimeter strips are not compressed during installation.

Any protruding perimeter strips should be cut off level with the finished floor.

Note:

With regard to fire protection requirements, mineral wool perimeter strips (e.g. fermacell) with a melting point $\geq 1\,000\text{ °C}$ should be used.

4.1.2 Tools

For fermacell Gypsum Fibreboard and Powerpanel H₂O Flooring Elements.

The flooring elements can be cut with standard tools. We recommend the use of hand-held circular saws with a guide and vacuum extraction. Blades should be carbide tipped and have approximately 16 teeth. A slower cutting speed reduces dust levels.

For small detail cuts use a jig saw or a hole saw. Wear suitable dust mask protection.

4.1.3 Installation Method

1 Place a perimeter isolation strip along the walls to avoid acoustic flanking transmission, and to allow for differential movement.

2 First row of boarding: Cut off protruding edges on two sides of the first element and on the long side of the following element.

3 Lay the **fermacell** Flooring Elements as shown in diagram 1.

If the **fermacell** Flooring Elements are being laid on dry levelling compound, we recommend that you work from the door to avoid disturbing the granules. This method is shown in

diagram 2.

The overlaps are only removed from the first row to ensure a tight fit against the wall. Use the off-cut from the end of the first row of flooring elements to start the next run of boards (minimum length 250 mm and leave the protruding edge in place), avoiding cross-joints.

4 The overlaps are glued with **fermacell** Flooring Adhesive (coverage: 20–25 m² per bottle). Follow the instructions on the packaging.

5 The boards are screwed or stapled together through the ship lap joints. This holds the edges securely whilst the glue expands through the joint and cures. Stand on the overlaying shiplap side when fixing boards together. This ensures a flat joint.

6 When the glue is dry and the excess has been scraped off, **fermacell** Joint Filler should be used, if required, to finishing the joints and screw or staple heads.

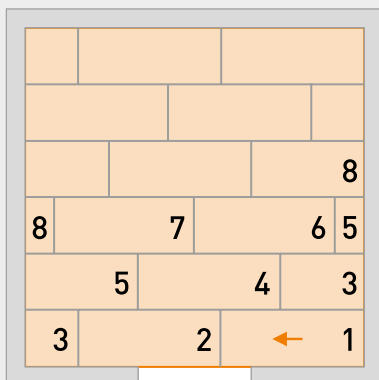

Installation diagram 2 – installation away from the door opening

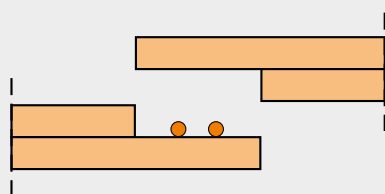

Glue bead approx. 5 mm Ø

TIP:

After applying the glue, place the bottle down so that any trailing glue can drop onto the shiplap edge.

Installation in Corridors

The flooring elements should be fitted longitudinally in corridors or in small rooms.

Wear Suitable PPE when installing **fermacell** Flooring Elements. If skin is contaminated with the flooring glue, then rinse off immediately with soap and water. Hands contaminated with glue must be immediately cleaned with soap and water. Refer to COSHH data sheets.

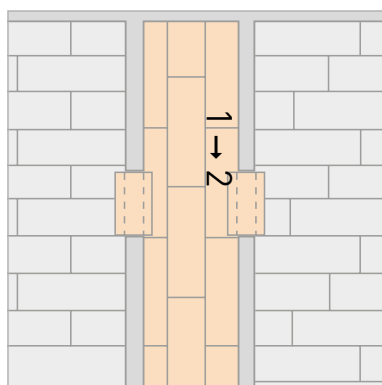

Installation diagram for Corridor (Details doorway see section 7.2)

Fixing of glued flooring joints

The elements must be screwed or stapled together within 10 minutes to prevent lipping due to the natural expansion of the glue.

Fixing Centres:

Screws:

- 200 mm for the **fermacell** Flooring Elements (**fermacell** Flooring Screws)
- 150 mm for Powerpanel H₂O Flooring Elements (Powerpanel flooring screws)
- 150 mm for **fermacell** Flooring Elements and Powerpanel H₂O Flooring Elements (**fermacell** Diverging Staples (chisel point))

To ensure a flat joint, stand on the upper overlapping flooring element, thus clamping the two elements together with your own body weight. This will give a tight joint while fixing the elements together.

Once hardened (approx. 24 hours at 20 °C and 65 % relative humidity), the **fermacell** Floor Glue should be scraped off with a **fermacell** Glue Scraper, spatula or a chisel.

fermacell Flooring Elements can be walked on carefully during installation.

The flooring elements are only fully weight-bearing once the **fermacell** Floor Glue has completely hardened (approx. 24 hours at a normal indoor climate 20 °C and 65 % humidity).



Apply perimeter strips and push into the perimeter junctions



Saw off any protruding edges for the first row



Install the **fermacell** Flooring Element



Apply the **fermacell** Floor Glue to the shiplap joint



Glue the elements to ensure fully bonded



Fix by screwing ... or stapling within 10 minutes - stand on the overlapping edge element

4.1.4 Increasing the load-bearing capacity of fermacell Flooring Elements - Installing a Third Layer

This can be simply achieved by adding either a 10 mm or 12.5 mm fermacell as a third layer.

Preparation

The floor surface must be ready for covering (see section 6) before installing the 3rd layer.

- Ensure the flooring is ready to receive an additional layer.
- Lay the 3rd layer at 90° to the base layers.
- minimum joint offset 200 mm.
- Apply beads of flooring glue in lines at 100 mm centres. Usage approx 7 m² per bottle (130-150 g/m²).
- apply the glue max. 10mm away from the joint edges.
- for installing with greeline Floor Glue, see the appropriate section on page 28.

Fix with **fermacell** Floor Screws or diverging Staples in a 250 mm x 250 mm grid pattern



Glue bead at the edge of the board

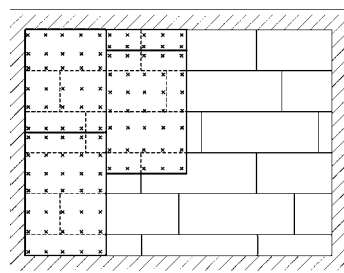

Installation diagram 3rd layer

4.2 fermacell Floor Glue greenline

As an alternative to **fermacell** Floor Glue, greenline Floor Glue may be used.

Usage

Shake **fermacell** greenline floor glue before use.

Jointing

Install in the same way as the standard floor glue.

Additional notes:

- Remove excess glue after 5-30 minutes with a scraper.
- Do not walk on the surface for 24 hrs. Leave to cure for this time at an ambient indoor climate of 20 °C and 50 % RH.
- Remove any hardened glue.
- After 73 hours the full load bearing capacity of the flooring element joints are achieved.

Glueing the 3rd layer

Glue and fit the 3rd layer as per the normal fermacell floor glue. N.B.: Glue beads (5 mm Ø) should be laid in lines at max 50 mm centres. Usage 350-400 g/m².



Material properties	
Usage	Shiplap Joint edge: approx. 40 g/linear metre (approx. 80-100 g/m ²) (10-12 m ² /bottle) 3 rd layer: approx. 350-400 g/m ² (2-3 m ² /bottle)
Glue usage temperature	min. +10 °C to max. +35 °C Recommended: +15 °C to +25 °C
Substrate and room temperature	≥ +5 °C
Accessibility of Floor	after approx. 24 hrs. (20 °C, 50 % RH)
Full load-bearing capacity of Floor	after approx. 72 hrs. (20 °C, 50 % RH)
Storage Instructions	18 months, cool, dry, protected from Frost*
Consistency	Viscous
Colour	Light green

* Short-term exposure to frost during transport and storage will not damage **fermacell** greenline Floor Glue.



4.3 Expansion/movement joints for fermacell Gypsum Fibreboard and Powerpanel H₂O Flooring Elements

Expansion joints

These are required at maximum 20 linear meter intervals.

These are not required at door openings or changes in areas.

They are required where there is a material change in the floor substrate (i.e. timber to concrete etc..)

Movement joints

(see section 7 for Details).

Main construction movement joints must be mirrored through both the substrate and the **fermacell** Flooring System.

The final position of expansion/movement joints in the flooring must be determined by the planner /designer on site, and in coordination with all relevant parties.

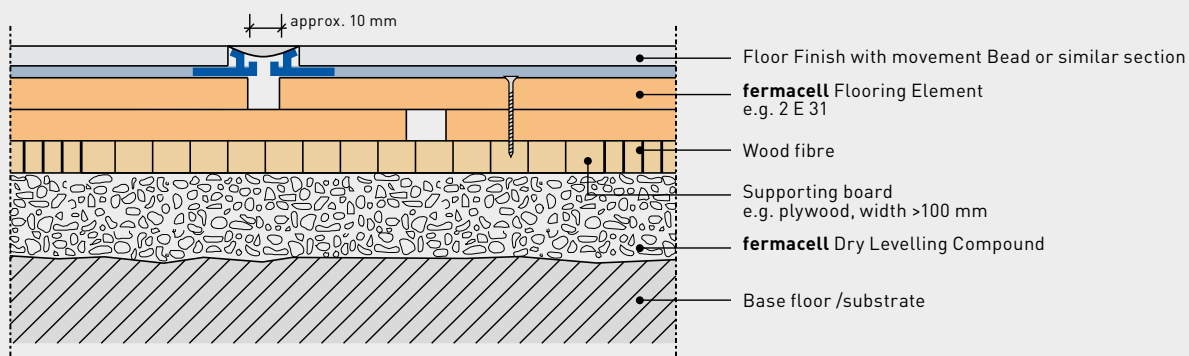

Movement joint on **fermacell** Dry Levelling Compound with **fermacell** 2E31 Flooring Element

5 Flooring exposed to moisture and humidity

5.1 Introduction

For areas of high humidity or exposure to moisture the substrate and surrounding area must be appropriately sealed and protected.

This protection can take the form of a waterproofing membrane or a proprietary sealing system, e.g. **fermacell** Waterproofing System.

For especially harsh environments a higher performance waterproofing system may be required, refer to manufacturers guidelines.



The cement-based **fermacell** Powerpanel H₂O Flooring Elements are suitable for wet areas.

Definition of humidity exposure classes - Guidance

The following is a reference guide based on German requirements.

For project specific requirements refer to the specification and relevant British & European Standards.

Exposure class	Type of exposure	Area of application
Humidity exposure classes for low or minor exposure areas . Refer to British Standards as required. In accordance with Bundesverband der Gipsindustrie e. V. "Bathrooms and wet rooms in timber and drywall construction", as at 02/2014		
0	Wall, floor and ceiling surfaces, which are only occasionally, slightly exposed to water spray for a short time.	<ul style="list-style-type: none"> ■ Guest WCs (no shower or bath facilities) ■ Kitchens for domestic use ■ on walls in the area of sanitary facilities e.g. hand washbasins and wall-hung WCs ■ on ceilings in bathrooms for domestic use
A0	Wall, floor and ceiling surfaces, which are only occasionally, moderately exposed to water spray for a short time.	In bathrooms for domestic use or hotel bathrooms directly in the water spray zone of showers and bathtubs with shower a screen, with and without a floor drain, e.g. showers
Humidity exposure classes in High Exposure approved areas (high exposure) Guidance Details - refer to British Standards for further information		
A	Wall and floor surfaces, with high exposure due to non-pressurised water in internal areas	Walls and floors in public showers

Suitable substrates for bonded waterproof membranes

	Humidity exposure classes		
	0	A0	A
	low	moderate	high
	Floor	Floor	Floor
fermacell Flooring Elements	○	DMR ¹⁾	—
fermacell Powerpanel H ₂ O Flooring Element	○	○ ²⁾	MR
Calcium sulphate flooring	○	DMR ¹⁾	—
Cement flooring	○	DMR	MR

¹⁾ Not permissible in areas with integrated floor drains (e.g. barrier-free shower areas)

²⁾ Edge junctions, movement joints and openings must be constructed with sealing tape and a liquid waterproofing application.

- Area without the need for waterproofing (to be waterproofed if deemed necessary and as instructed by the client or designer)
- Application not permitted
- D Polymer dispersion system = **fermacell** Waterproofing Application
- M plastic-cement mortar combination
- R Specialist Resin Solution

Note:

fermacell Flooring

Elements are not suitable for areas of High humidity such as Swimming Pools, Wet rooms, Changing and showering areas in leisure centres

5.2 Waterproofing systems

The **fermacell** Waterproofing System is a bonded waterproof membrane, which is applied directly to the fermacell boards, consisting of:

- **fermacell** Deep Primer,
- **fermacell** Waterproofing Application (polymer dispersion),
- **fermacell** Flexible Sealing Tape,
- **fermacell** internal/external corner sections,
- **fermacell** pipe penetration patches
- and **fermacell** Flexible Tile Adhesive (thin-bed mortar) or other approved flexible tile adhesives

Note:

With regard to waterproofing systems for extreme and high level humidity exposure, please contact specialist manufacturers for their guidelines.

In all cases refer to Relevant Country Standards.

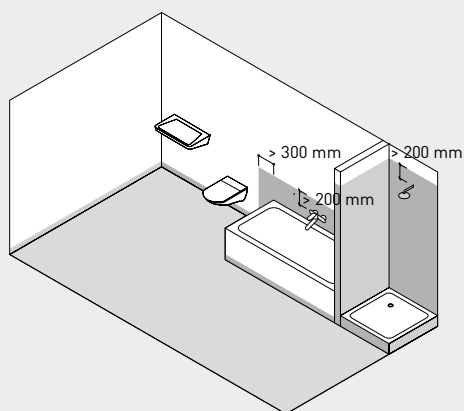

Shower with raised shower tray

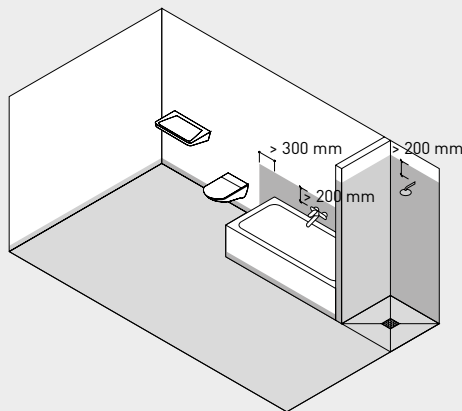

Shower with in-built floor drain

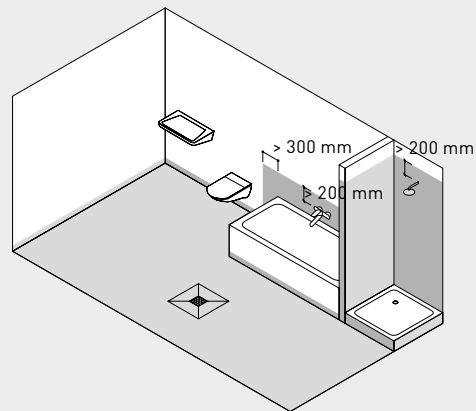

Domestic bathroom with bath and shower

 No or low exposure to waterspray (exposure class 0)

 Moderate exposure to waterspray (waterspray zone, exposure class A0)

5.3 Installing the waterproofing system

Fit the required **fermacell** or Powerpanel Flooring Elements as described in chapter 4. Ensure surfaces are clean, level and flat.

Finish any joints as shown below:

- **fermacell** Flooring Elements with **fermacell** Joint Filler
- **fermacell** Powerpanel H₂O Flooring Elements with Powerpanel surface finish (see section 3.3 – filling/levelling)

Apply the waterproofing system as shown in the details below.

Installation sequence – fermacell Waterproofing System



1 Apply **fermacell** Deep Primer to perimeter wall area ...



2 ... and floor area using a roller



3 Apply **fermacell** Waterproofing Application to the internal corners



4 Press **fermacell** Flexible Sealing Tape into the wet waterproofing application



5 Immediately apply a coating of **fermacell** Waterproofing Application to the Sealing Tape



6 When using **fermacell** Powerpanel H₂O Flooring Element only apply the **fermacell** Waterproofing System to the internal corner areas.

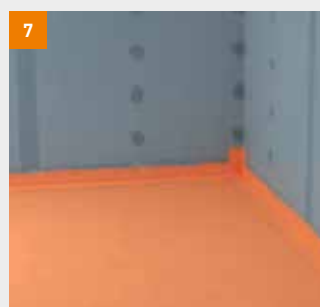

7 When using **fermacell** Flooring Elements, the entire surface must be completely waterproofed



8 For the **fermacell** Powerpanel H₂O Flooring Shower Element, the waterproofing system is applied to all joint areas

6 Floor coverings

6.1 Installation Tolerance Guidelines

The following table shows the guideline values for tolerance levels on completed fermacell floors*

Measurement section (m)	Allowable Tolerance measurement (mm)
1.00	3
2.00	5
4.00	9

* Depending on the project requirements, different tolerances's may be required.

The maximum height difference at the joints between elements must not exceed 2 mm.

The maximum displacement of the dry flooring construction relevant to the permissible point load allowance at the perimeter must not exceed 3 mm.

The flooring elements are ready for application of a covering or final finish when they have acclimatised. This is normally achieved after 48 hours at an ambient air temperature above 15 °C and max. 70 % relative humidity.

The following moisture content value must not be exceeded:

■ **fermacell** Gypsum Fibre 1.3 % (mass percent according to the Darr method)

The floor surface including the joints must be dry, solid and free of stains, dust and grease.

Any residue **fermacell** Floor Glue must be scraped off (see section 4.1.4) surfaces contaminated with glue will compromise the adhesion of other surface finishes.

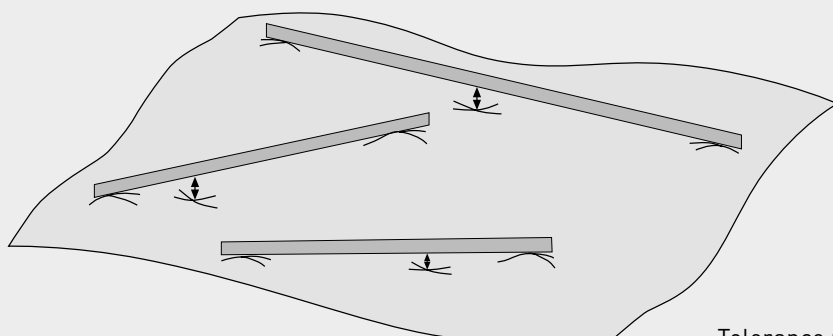

Tolerance measurements for **fermacell** Flooring Elements

6.2 Carpeting, PVC, cork and other floor coverings

- When laying self-adhesive carpet tiles and waterpermeable floor coverings, the use of a suitable primer is recommended.
- Carpeting should be secured with double-sided adhesive tape.
- If a carpet is to be bonded to over the entire area of the floor, we recommend the use of a peel-off adhesive system that will allow the carpet to be taken up in one piece at a later date; without leaving pieces of carpet glued to the **fermacell** Flooring Elements.
- When laying non-permeable floor coverings it is advisable to use a reactive resin-based adhesive, not a dispersion-based adhesive.

For thin floor coverings (carpet, PVC, etc.) in broadloom or tile form the entire floor surface should be treated with a suitable self levelling feather screed. These feather screeds should be suitable for use with a gypsum based board. These are applied in liquid form, drying to form a perfectly flat, level surface. This is to ensure that between the elements and the final finish any slight protrusions or indentations made by the fastenings – do not show through the floor covering when laid.

The self levelling compound must be completely dry before proceeding with the next stage of the work. The drying times specified by the manufacturer must be observed.

In the case of thicker carpeting material, it is normally sufficient to apply a thin layer of **fermacell** Joint Filler to the joints between boards, and to fill in the slight indentations left by the screws or staples.



Textile



PVC



Carpet



6.3 Ceramic tiles, natural stone paving and terracotta tiles

- Tiles should only be laid in a 'Thin Bed' adhesive method. We do not advise the use of 'Thick Bed' adhesive methods. Should these be required, then a suitable decoupling membrane should be used.
- Tiles may be fixed with a polymer-modified cement based tile adhesives, emulsion-based adhesives or reactive resin adhesives which have been approved by the manufacturer for use with gypsum based boards for flooring applications.
- Tiles should not be soaked prior to fixing, and at least 80 % of the back of the tile must be in contact with the adhesive bed (lift the occasional tile to check adhesion).
- The foam isolation strip laid around the perimeter of the floor to prevent sound bridging should be trimmed back level with the finished floor only after all tiling and grouting work has been completed.
- Tiles should always be laid with open joints. Tiles should never be laid with tightly butted joints, as this may lead to the formation of capillary joints.
- Grout the tiles only when the tile adhesive has fully hardened, i.e. when all the moisture in the adhesive has evaporated through the open joints. This normally takes about 48 hours, depending on the ambient temperature and humidity.
- Internal corners must be sealed with a suitable elastic sealant, such as silicone (with a movement accommodation factor of 20 % or more).
- The application of a thin layer of **fermacell** Joint Filler to fill in and smooth over the joints between boards and to fill in the slight indentations left by the screws or staples is only required when used in conjunction with a waterproofing or proprietary sealing system' (see also page 30, "Floors exposed to moisture").

Ceramic floor tiles

fermacell Flooring Elements are suitable for the fixing of floor or mosaic tiles. Larger floor tiles (300 mm square or more) are generally unsuitable for thinbed fixing, since the nature of the manufacturing process (firing at high temperatures) makes it impossible to guarantee the flatness of the tile. However, if the tile manufacture allows the use of a thin bed adhesive method with their tile, then follow the manufacturers instructions for fixing larger tiles.

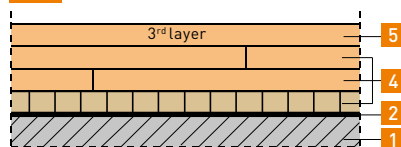

Advice regarding the use of large-format tiles on **fermacell** Flooring Elements in living areas

A

fermacell flooring element with additional 3rd layer, without additional insulation, e.g. 2 E 31
Levelling only with **fermacell** Self-Levelling Compound, Bonded Levelling Compound, Honeycomb Insulation System

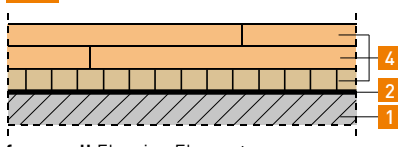
B

fermacell Flooring Element without additional insulation, e.g. 2 E 31

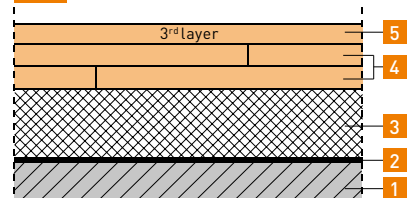
C

fermacell Flooring Element with additional insulation and 3rd layer, e.g. 2 E 22 with 3rd layer on EPS hard foam insulation

Legend

- 1 Base floor
- 2 Levelling layer (optional)
- 3 Additional insulation/underfloor heating
- 4 **fermacell** Flooring Element
- 5 3rd layer of fermacell

1 Base floors

Sufficiently rigid

- Solid floor or edge-glued timber floor
- Timber-joint floor, Limiting deflection of floor joists and the structural, load-bearing boarding – max. $l/500$

2 Levelling (optional)

Levelling options underneath all flooring constructions – without reducing the tile sizes:

- 10 to 30 mm **fermacell** Levelling Compound with an overlay layer of 10 mm **fermacell** Gypsum Fibreboard or
- Self-Levelling Compound or
- **fermacell** Bonded Levelling Compound
- **fermacell** Honeycomb Insulation System 30 or 60 mm

3 Additional insulation/underfloor heating

- Only use insulation or underfloor heating, which is suitable for use underneath the corresponding **fermacell** Flooring Element relevant to the area of application 2²¹.
- Suitable underfloor heating systems must be clarified with the respective system manufacturer.

5 3rd layer

4 fermacell Flooring Elements

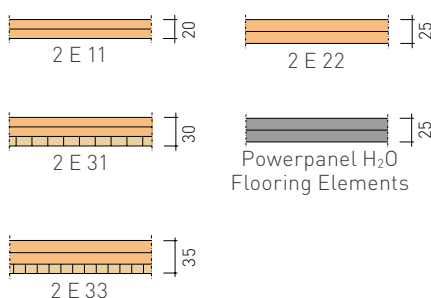

- Installation of an additional 10 mm thick **fermacell** Gypsum Fibreboard

Installation techniques

- Installation of tiles with a thin-bed method on **fermacell** Flooring Elements
- Installation of tiles with a thin or medium-bed method on **fermacell** Powerpanel H₂O Flooring Elements
- Full-surface embedding of tiles into the adhesive bed is recommended
- Only system-compatible products (primer, tile adhesive, etc.) should be used, which are specifically approved by the respective manufacturer for the corresponding areas of application, tile sizes and substrates.
- Grouting can only be carried out once the adhesive has set (observe manufacturer guidelines).

Tile layout

■ Aspect ratio 1:1 to 3:1 in regard to construction options B + C in the following table.

Allowable tile sizes on fermacell in living areas ³⁾ (Area of application 1¹⁾, point load 1 kN)

Tile Size	fermacell Flooring Element		2 E 11	2 E 31 2 E 33	2 E 22	Powerpanel H ₂ O Flooring Elements
Ceramic-tiles sizes shown in mm (min. thickness 9 mm)						
max. 330	without additional insulation	A	●	●	●	●
	with additional insulation	B	●	●	●	●
	with additional insulation and 3 rd layer	C	●	●	●	-
max. 450	without additional insulation	A	●	●	●	●
	with additional insulation	B	-	-	●	●
	with additional insulation and 3 rd layer	C	●	●	●	-
max. 600	without additional insulation	A	●	●	●	●
	with additional insulation	B	-	-	●	●
	with additional insulation and 3 rd layer	C	●	●	●	-
max. 800	without additional insulation	A	●	●	●	●
	with additional insulation	B	-	-	-	-
	with additional insulation and 3 rd layer	C	-	-	●	-
max. 1 200	without additional insulation with 3 rd layer	A	●	●	●	●
	without additional insulation	B	-	-	-	-
	with additional insulation and 3 rd layer	C	-	-	-	-

Natural stone tiles sizes shown in mm (min. thickness 15 mm)						
max. 330	without additional insulation	A	●	●	●	●
	with additional insulation	B	●	●	●	●
	with additional insulation and 3 rd layer	C	●	●	●	-
max. 450	without additional insulation	A	●	●	●	●
	with additional insulation	B	-	-	●	●
	with additional insulation and 3 rd layer	C	●	●	●	-
max. 600	without additional insulation	A	●	●	●	●
	with additional insulation	B	-	-	-	-
	with additional insulation and 3 rd layer	C	-	-	●	-
max. 800	without additional insulation with 3 rd layer	A	●	●	●	●
	without additional insulation	B	-	-	-	-
	with additional insulation and 3 rd layer	C	-	-	-	-

● suitable - NOT suitable

Type and maximum height of additional insulation shown in mm (maximum 1 layer)				
EPS rigid insulated DEO 150 kPa	≤ 70	≤ 60	≤ 90	≤ 90
EPS rigid insulation DEO 200 kPa or XPS DEO 300 kPa	≤ 100	≤ 90	≤ 120	≤ 120
Other additional insulation materials	-	-	Insulation or underfloor heating, minimum requirement - area of application 2²⁾	

1) Area of application 1; point load 1,3 kN; 2) Area of application 2; point load 2,0 kN; 3) Area of application 3; point load 3,0 kN;

Example: Ceramic tiles

(minimum thickness 9 mm)



Up to 1200 mm laid over **fermacell** 2 E 11, 2 E 22, 2 E 31/33, H₂O Flooring Element; each with additional 3rd layer but without additional insulation



Up to 800 mm laid over **fermacell** 2 E 11, 2 E 22, 2 E 31/33, H₂O Flooring Element; each without additional insulation and without additional 3rd layer



Up to 800 mm laid over **fermacell** 2 E 22, H₂O Flooring Element; each with additional insulation and 3rd layer

6.4 Parquet, laminate

Parquet, solid timber and laminate flooring.

- **fermacell** Flooring Elements are suitable as a substrate for laminate flooring as well as mosaic or herringbone parquet.
- **fermacell** Flooring Elements are not suitable as a substrate for solid timber flooring including parquet and solid strip flooring, unless it is laid as a floating floor or using special installation techniques. Please call our Technical helpline for further information.
- Laminate timber flooring, including parquet can be laid as a floating or bonded floor (refer to manufacturer's recommendations).
- Mosaic parquet must be laid in a box or herring bone pattern, to ensure that there is sufficient allowance for movement of the timber in all directions.
- With these types of overlay finishes it is not necessary to fill the joints or fixing heads in the **fermacell** Flooring Elements. The appropriate British Standards must be followed in respect of laying, surface finish and quality of the parquet floor.
- The moisture content of any wood flooring, when installed, must correspond to the requirements of the relevant British Standard.
- For bonded parquet floors ensure that only primers, sealers and adhesives specifically designed for gypsum based substrates are used.

We recommend the use of low water content primers, sealers and adhesives. These must be applied in accordance with the manufacturer's instructions.



Parquet

7 Details

7.1 Construction details (example illustrations)

7.1.1 Thermal insulation of floors using **fermacell** Flooring Elements or **Powerpanel H₂O** Flooring Elements

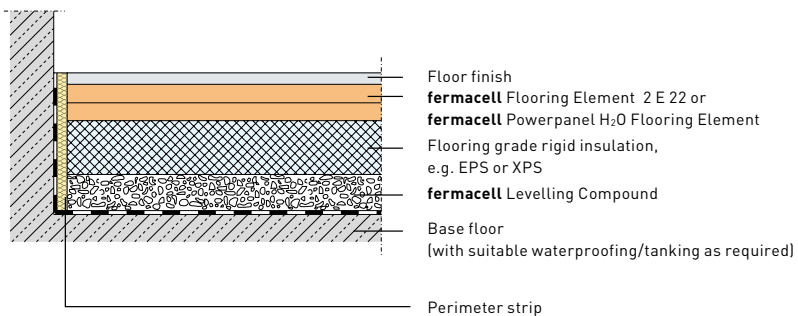

7.1.2 Levelling of wooden-joist floors with **fermacell** Flooring Elements

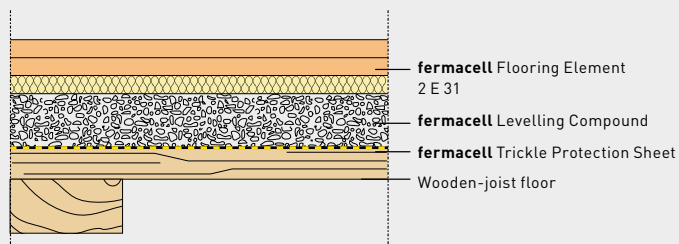

with **Powerpanel H₂O** Flooring Elements

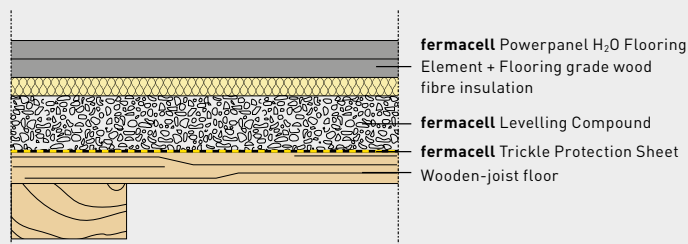

7.1.3 Levelling of wooden-joist floor with load-bearing supports between joist section with **fermacell** Flooring Elements

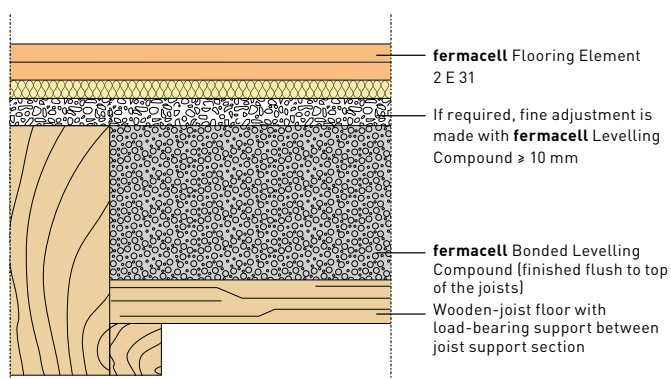

with **Powerpanel H₂O** Flooring Elements

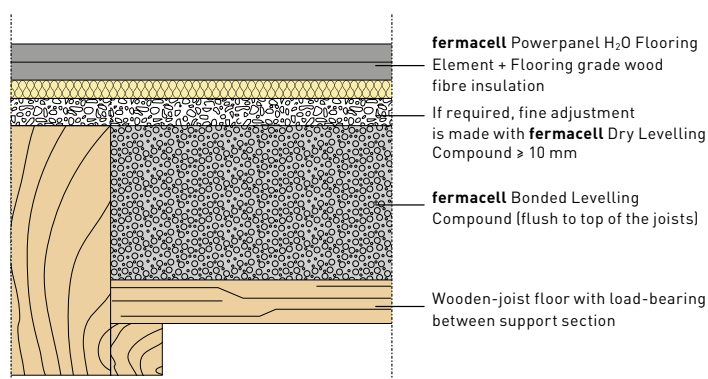

7.1.4 Levelling to vaulted ceiling with fermacell Flooring Elements or Powerpanel H₂O Flooring Elements (building structural details and requirements must be taken into account)

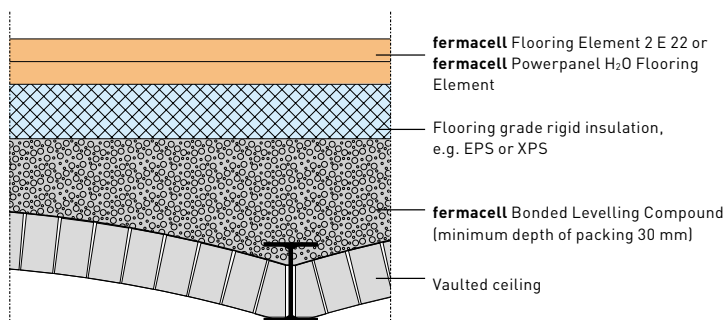

7.1.5 Trapezoidal steel sheet floor with fermacell Flooring Elements

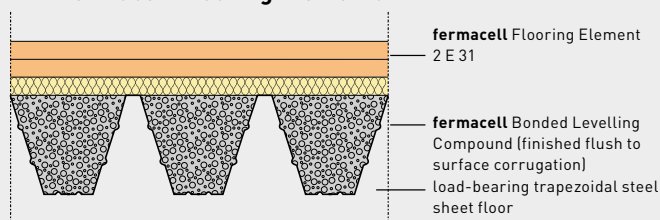

with Powerpanel H₂O Flooring Elements

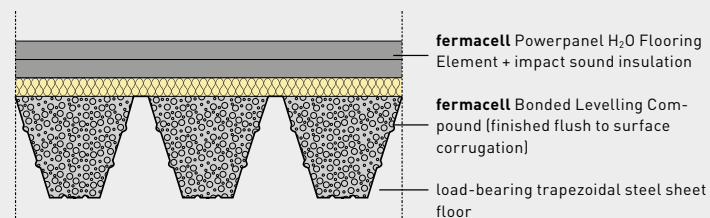

7.1.6 Trapezoidal steel sheet floor with fire exposure from above with fermacell Flooring Elements or Powerpanel H₂O Flooring Elements

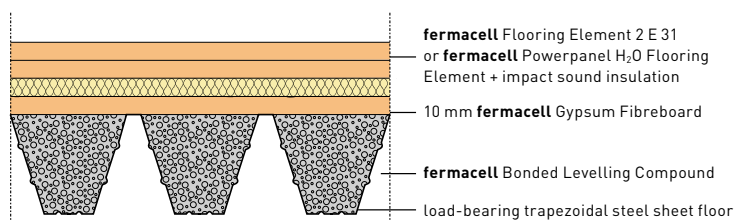

7.1.7 Covering of service pipes and cables with fermacell Levelling Compound, overlaid with fermacell Flooring Elements

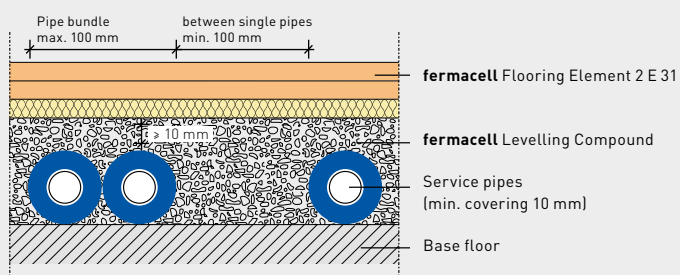

with Powerpanel H₂O Flooring Elements

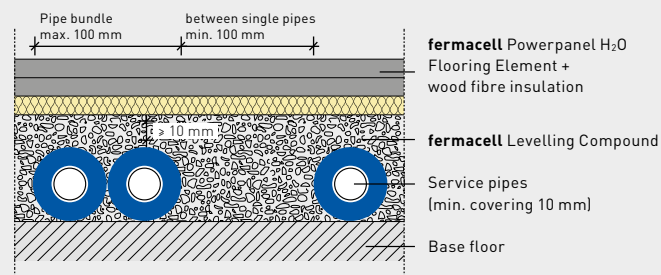

7.1.8 Embedding service pipes and cables in fermacell Bonded Levelling Compound, overlaid with fermacell Flooring Elements

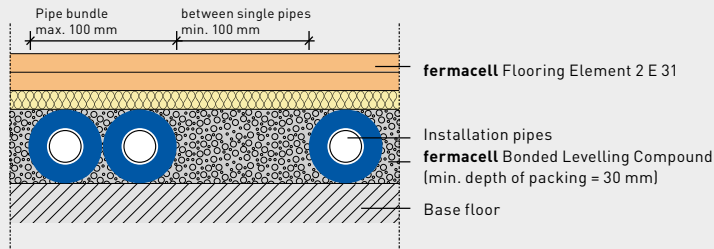

with Powerpanel H₂O Flooring Elements

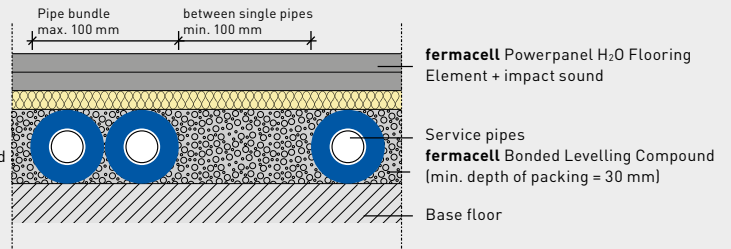

7.1.9 Junction to a wall in moisture affected areas with fermacell Flooring Elements or Powerpanel H₂O Flooring Elements

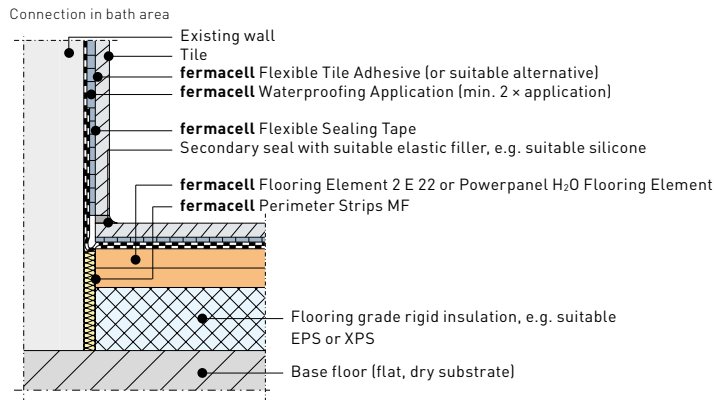

7.1.10 Movement joint to accommodate a material change of fermacell Flooring Elements to Powerpanel H₂O Flooring Elements

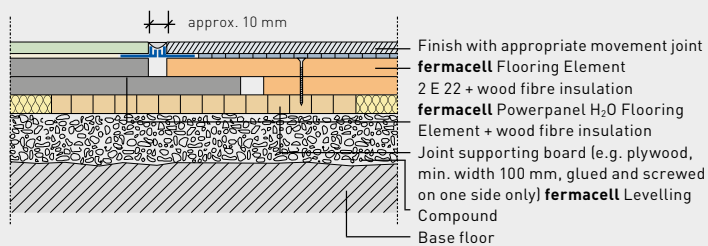

7.1.11 Movement and Construction joint to a solid structural element with fermacell Flooring Elements or Powerpanel H₂O Flooring Elements

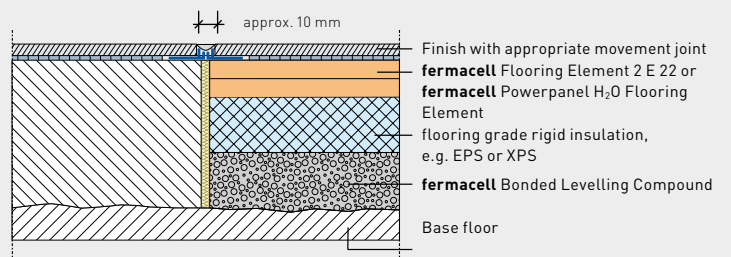

7.1.12 Movement joint on a suitable underfloor heating system or insulation with fermacell Flooring Elements or Powerpanel H₂O Flooring Elements

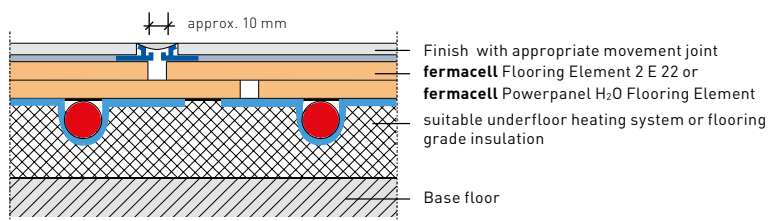

7.1.13 Ground-level concrete floor

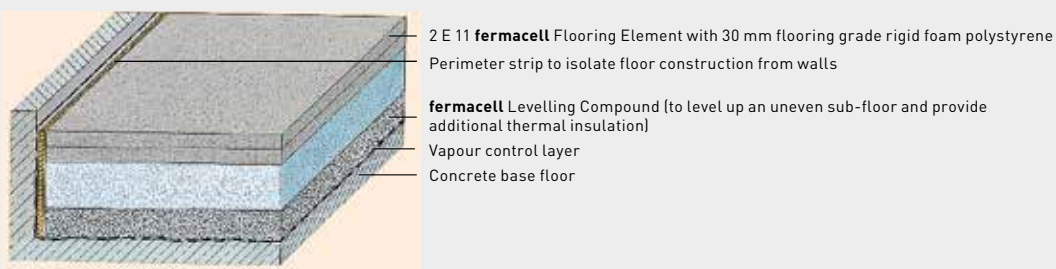

7.1.14 Suspended timber floor with uneven floorboards

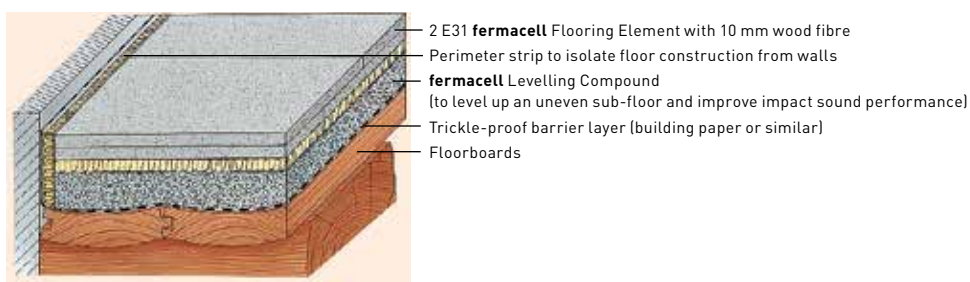

7.1.15 Solid concrete floor, stepped construction

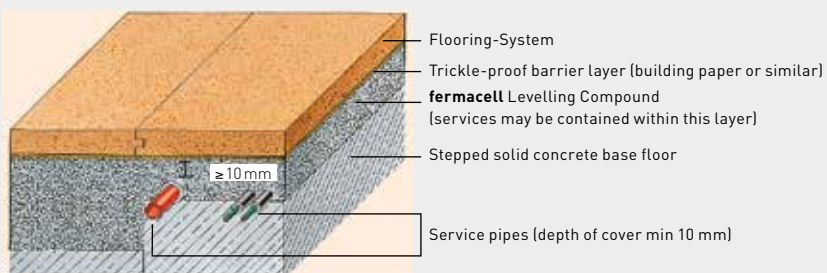

7.2 Doorway Detail – Option 1: fermacell Flooring Elements T-jointed

T-Joint at Door Threshold between two rooms.

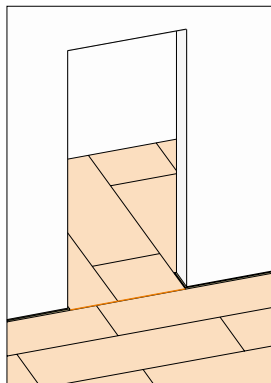

Junction: T- junction **fermacell** Flooring Elements junction in the door area, without a solid bond

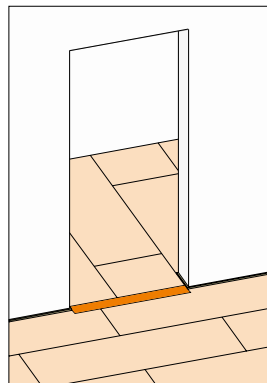

Solution: Simple joint detail at the door threshold area.

Installation procedure

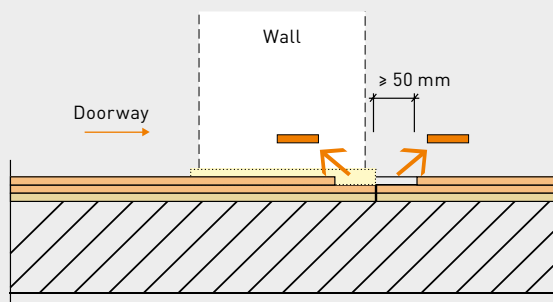

1. Cut out a ≥ 50 mm wide **fermacell** Strip from the upper layer on each side, e.g. with a hand-held circular saw

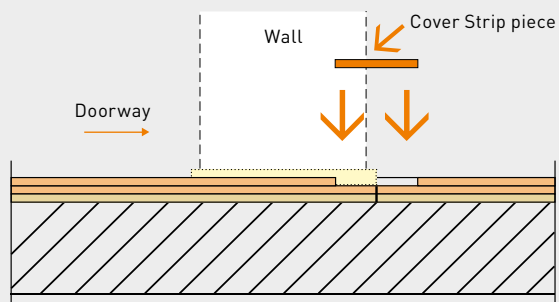

2. Cut a cover strip (suitable length, width and thickness) of **fermacell** Gypsum Fibreboard. Apply **fermacell** Floor glue to the both lower sections and then position the cover strip piece

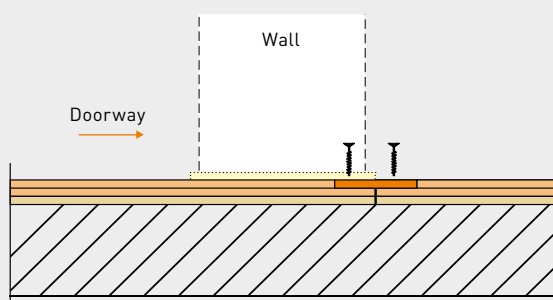

3. Fix **fermacell** Cover Strips and flooring element together with **fermacell** Flooring Screws or diverging staples. Maximum spacing between fixings 150 mm

7.3 Doorway Detail – Option 2: fermacell Flooring Elements installed parallel

Joint at a Door Threshold between two rooms.

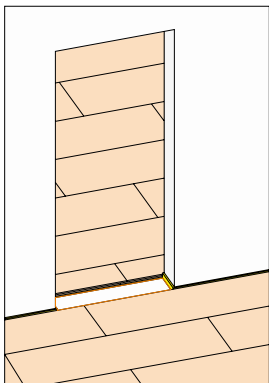

Junction: When installing the **fermacell** Flooring Elements, leave doorway clear

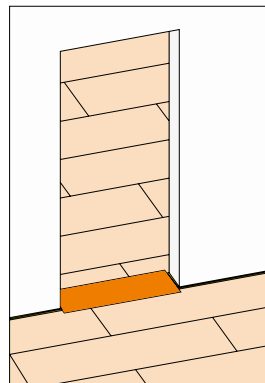

Solution: Finished infill section in door threshold area

Installation Steps

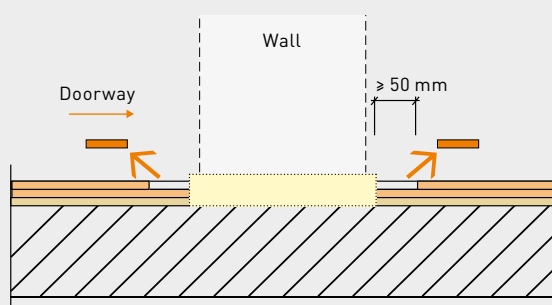

1. Cut out a ≥ 50 mm wide **fermacell** Strip from the upper layer on each side, e.g. with a hand-held circular saw

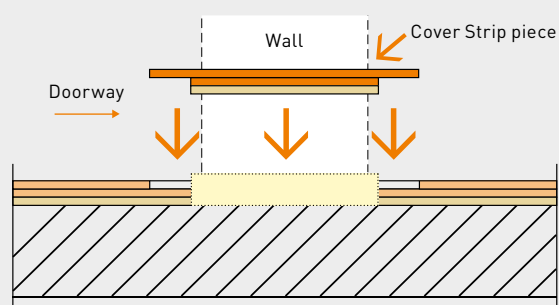

2. Cut an infill piece (suitable length and width) from a **fermacell** Flooring Element. Apply **fermacell** Floor Glue to the overlap edges and then position the cover strip piece

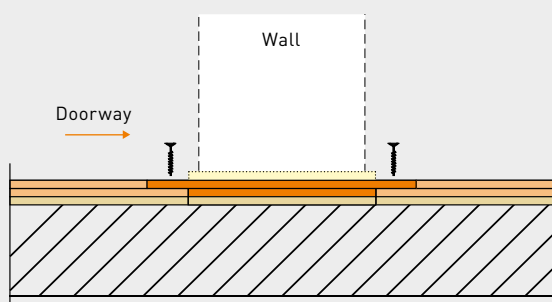

3. Fix both elements together, with **fermacell** Flooring Screws or diverging staples. Maximum spacing between fixings 150 mm

Advantages:

Monolithic joints at door areas. No step in the transition areas between rooms.

8 Technical Data and Specifications

8.1 fermacell Flooring Elements

The elements consist of two pre bonded 10 mm or 12.5 mm thick **fermacell** Gypsum Fibreboards. The two boards are staggered, to give a 50 mm wide shiplap edge. The elements are 1500 mm x 500 mm in size (area 0.75 m²).

8.2 fermacell Power-panel H₂O Flooring Element

The elements consist of two prebonded 12.5 mm thick Powerpanel H₂O boards. The two boards are staggered, to give a 50 mm wide shiplap edge elements are 1250 mm x 500 mm in size (area 0.625 m²).

Technical Data – fermacell Gypsum Fibreboards	
Density (production specification) ρ_K	1150 ± 50 kg/m ³
Water vapour diffusion resistance coefficient μ	13
Coefficient of thermal conductivity λ	0.32 W/mK
Specific heat capacity c	1,1 kJ/kgK
Brinell hardness	30 n/mm ²
Thickness swelling after 24 hours of water immersion	< 2 %
Coefficient of thermal expansion	0.001 %/K
Expansion/shrinkage with a change in relative humidity of 30 % (20 °C)	0.25 mm/m
Equilibrium moisture content at 65 % relative humidity and a 20 °C air temperature	1.3 %
Building material class according to DIN EN 13501-1 (non-combustible)	A 2
pH-value	7–8

Technical Data – Powerpanel H ₂ O Flooring Element	
Building material class according to DIN EN 13501-1 (non-combustible)	approx. 10
pH-value	
Density (production specification) ρ_K	1000 kg/m ³
Water vapour diffusion resistance coefficient μ	56 acc. DIN EN 12572
Coefficient of thermal conductivity λ	0.173 W/mK acc. DIN EN 12664
Specific heat capacity c	1.0 kJ/kgK
Equilibrium moisture at 65 % relative humidity and 20 °C air temperature	approx. 5 %

8.3 Technical Data and specifications of fermacell Flooring Elements

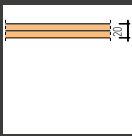
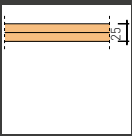
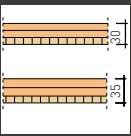
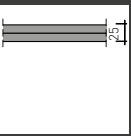
				
fermacell Flooring Element	2 E 11	2 E 22	2 E 31 (2 E 33)	Powerpanel H ₂ O Flooring Element
System construction	2 x 10 mm Gypsum Fibre- board	2 x 12.5 mm Gypsum Fibre- board	2 x 10 mm (2 x 12.5 mm) Gypsum Fibre- board + 10 mm wood fibre WLG 050	2 x 12.5 mm Powerpanel H ₂ O Flooring Element
Element thickness (mm)	20	25	30 [35]	25
Weight (kN/m ²)	0.23	0.29	0.25 [0.31]	0.25
Thermal resistance (m ² K/W)	0.06	0.08	0.26 [0.28]	0.14
Building material class according to DIN EN 13501 or * DIN 4102	A _{2fl} -s1	A _{2fl} -s1	B _{fl} -s1	A1*

8.4 Accessories

Technical Data fermacell Self-Levelling Compound	
Building material class	A1
Coefficient of thermal conductivity λ_R	1.1 W/mK
Density	1700–1800 kg/m ³
max. layer thickness	20 mm
Material usage per m ²	approx. 1.4 kg per 1 mm layer thickness
Compressive strength (DIN 1164)	approx. 26,0 N/mm ²
Flexural strength (DIN 1164)	approx. 6,5 N/mm ²
Chair roll resistance acc. DIN 68131 or EN 12529	from min. 1 mm layer thickness
Weight per 10 mm layer thickness	0.17 kN/m ²
Storage	9 months dry

Technical Data fermacell Levelling Compound	
Building material class	A1 (to DIN 4102)
Coefficient of thermal conductivity λ_R	0.09 W/mK
Grain size	0.2 to 4 mm
Bulk Density	approx. 400 kg/m ³
min. layer thickness	10 mm
max. layer thickness (uncompacted)	100 mm area of applica- tion 1 60 mm areas of applica- tion 2–4
Material Usage per m ²	approx. 10 litres per 10 mm depth of levelling
Weight per 10 mm layer thickness	0.04 kN/m ²
Storage	dry

Technical Data fermacell Bonded Levelling Compound	
Building material class	A2 (to DIN 4102)
Coefficient of thermal conductivity λ_R	0.10 W/mK
Compressive strength (DIN 53421)	0.4 to 0.5 N/mm ²
Dry bulk density	approx. 350 kg/m ³
min. layer thickness	30 mm
max. layer thickness	2.000 mm (in layers up to 500 mm)
Material Usage per m ²	approx. 10 litres per 10 mm depth of levelling
Vapour diffusion co-efficient (DIN 52615)	$\mu = 7$
Weight per 10 mm layer thickness	0.035 kN/m ²
Storage	6 months Dry and frost-free

Technical Data fermacell Honeycomb Infill	
Building material class	A1 (acc DIN 4102)
Coefficient of thermal conductivity λ_R	0.7 W/mK
Grain size	1 to 4 mm
Bulk density	approx. 1.500 kg/m ³
min. layer thickness	30 mm
max. layer thickness	60 mm
Material Usage per m ²	approx. 10 litres per 10 mm depth of levelling
Weight	0.45 kN/m ² for 30 mm honeycomb 0.90 kN/m ² for 60 mm honeycomb
Storage	dry

9 Building physics / Construction performance

9.1 Fire protection from above for flooring constructions

9.1.1 Fire protection

fermacell Flooring Elements can also be used to improve the fire protection classification of different types of base floor constructions. Classifications from

F 30 to F 120 can be achieved from **fermacell** Flooring Elements laid over the corresponding type of base floor. Variations on performance can be achieved as shown below.

The fire protection of the systems are shown in the table below:

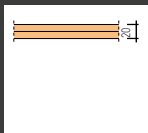
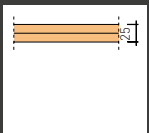
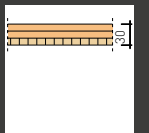
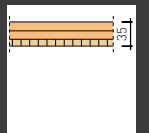
					
fermacell Flooring Element	2 E 11	2 E 22	2 E 31	2 E 33	
Construction	2 x 10 mm Gypsum Fibreboard	2 x 12,5 mm Gypsum Fibreboard	2 x 10 mm Gypsum Fibreboard + 10 mm wooden fibre	2 x 12.5 mm Gypsum Fibreboard + 10 mm wooden fibre	
Fire protection without any additional layers	F 60	F 60	F 60	F 60	
Design options for supplementary layers /build ups below the fermacell Flooring Elements					
fermacell Gypsum Fibreboard	10 mm	F 60	F 60	F 120	F 120
fermacell Levelling Compound	≥ 20 mm ≥ 40 mm ≥ 60 mm	F 60 F 90 F 120	F 60 F 90 F 120	F 60 F 90 F 120	F 60 F 90 F 120
fermacell Bonded Levelling Compound	≥ 40 mm ≥ 60 mm	F 90 F 120	F 90 F 120	F 90 F 120	F 90 F 120
fermacell Honeycomb Infill	≥ 30 mm	F 120	F 120	F 120	F 120

The fire protection improvement of types of base floor systems

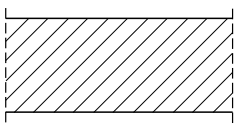
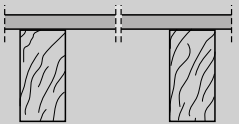
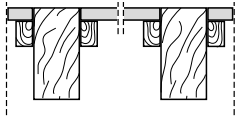
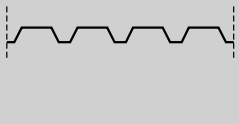
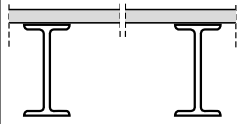
Concrete Floor + drawing	Wooden joist floor with a structural overlay board	Wooden joist floor with load-bearing in-fill side supports with a structural overlay board	Steel Profiled Sheet + Concrete	Steel Beam Floor
				
Minimum thickness based on the static loading requirements	Timber-based boards $t \geq 16 \text{ mm } \rho \geq 600 \text{ kg/m}^3$ Plywood boards $t \geq 16 \text{ mm } \rho \geq 520 \text{ kg/m}^3$ sheets/boards $t \geq 21 \text{ mm}$	Timber-based boards $t \geq 16 \text{ mm } \rho \geq 600 \text{ kg/m}^3$ Plywood boards $t \geq 16 \text{ mm } \rho \geq 520 \text{ kg/m}^3$ sheets/boards $t \geq 21 \text{ mm}$	Measurement of trapezoidal steel profiles based on the static loading requirements Please note the special requirements of the AbP certificate Additional layers may be required	Measurement of steel beams based on the static loading requirements Ceilings with 16mm thick timber or concrete-based boards, or others suitable alternatives

* The base floors including their load bearing performance and reinforcing components should be designed in accordance with the dynamic and static load requirements for their intended use

9.2 Sound insulation with fermacell Flooring Elements

Introduction

Sound performances are shown as laboratory figures, these are as defined in BS EN ISO 717: Part 1 2013 for airborne sound, and BS EN ISO 717: Part 2 for impact sound.

The performance figures indicated for fermacell solutions are laboratory tests and do not include for any Flanking sound transmission influence.

For site performance, these laboratory figures can then be taken as a guide on to which workmanship and flanking influence must also be taken into account.

Fermacell take no responsibility for any issues in performance due to incorrect workmanship, detailing and/or structural flanking influence. In some cases a 'guidance' or 'expected' performance may be indicated as not all system combinations can be tested.

Reference values for airborne and impact sound insulation.

R_w: Laboratory sound insulation measurement without the influence of flanking sound transmission

D_{n,T,w}: Site sound insulation single figure measurement taken between two adjacent rooms in a building. This result will be directly influenced by not only the separating element, but also any flanking, interface and junction details.





L'_{n,w}: Laboratory single figure timber level in dB

Performance requirements

Refer to the relevant performance requirement specifications for the areas of intended use. e.g.

- flats
- Apartments
- Schools
- Hospitals
- Offices
- etc...

Standard Base floor – Construction Details

	Construction	Sound insulation		Page
		Impact $L_{n,w}$	Airborne R_w	
		dB	dB	
	Open timber joist floor 22 mm spanning wood-based board 220 mm joist	90	28	51
	Closed timber joist floor, suspended ceiling on battens 22 mm wood-based board 220 mm joist 50 mm cavity insulation 30 mm batten at 400 mm centres, 10 mm fermacell	78	42	52
	Closed timber joist floor, flexibly suspended ceiling 22 mm wood-based board 220 mm joist 50 mm cavity insulation 30 mm Protektor TPS, at 400 mm centres 10 mm fermacell	62	55	54
	Solid floor 315- 400 kg/m² 160 mm reinforced concrete floor	78	55	56





Base floor

$R_w = 28 \text{ dB}$

$L_{n,w} = 90 \text{ dB}$

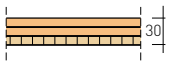
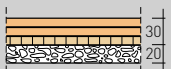
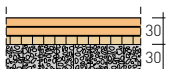
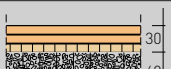
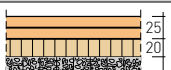
Open Timber joist floor

System drawing	Construction	Constr. height	Sound insulation Impact $L_{n,w}$	Airborne R_w	Area of application
		mm	dB	dB	
	2 E 31 (2 x 10 mm Gypsum Fibreboards + 10 mm Wood Fibre)	30	81	43	3
	2 E 31 (2 x 10 mm Gypsum Fibreboards + 10 mm Wood Fibre) auf 20 mm Levelling Compound	50	72	47	3
	2 E 31 (2 x 10 mm Gypsum Fibreboards + 10 mm Wood Fibre) on 30 mm Honeycomb Insulation System	60	63	58	3
	2 E 31 (2 x 10 mm Gypsum Fibreboards + 10 mm Woodfiber) on 60 mm Honeycomb Insulation System	90	61	61	3
	2 E 22 (2 x 12.5 mm Gypsum Fibreboards) on 20 mm Steico Therm on 60 mm Honeycomb Insulation System	105	56	65	2
	2 E 16 (2 x 10 mm Gypsum Fibreboards + 9 mm Felt)	29	79	35	3





Base floor

$R_w = 42 \text{ dB}$

$L_{n,w} = 78 \text{ dB}$

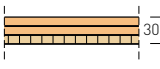
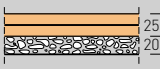
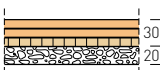
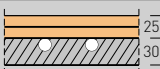
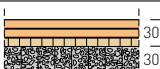
Closed timber joist floor, suspended ceiling on battens

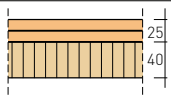
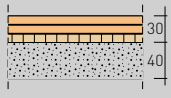
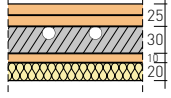
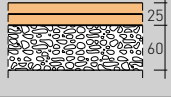
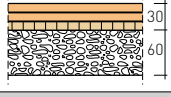
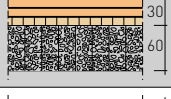
System drawing	Construction	Constr. height	Sound insulation Impact $L_{n,w}$	Airborne R_w	Area of application
		mm	dB	dB	
	2 E 31 (2 x 10 mm Gypsum Fibreboards + 10 mm Wood Fibre)	30	72	48	3
	2 E 22 (2 x 12,5 mm Gypsum Fibreboards) with 20 mm Levelling Compound	45	71	52	3
	2 E 31 (2 x 10 mm Gypsum Fibreboards + 10 mm Wood Fibre) with 20 mm Levelling Compound	50	69	51	3
	2 E 22 (2 x 12,5 mm Gypsum Fibreboards) with 30 mm EPS Underfloor Heating	55	70	51	1
	2 E 31 (2 x 10 mm Gypsum Fibreboards + 10 mm Wood Fibre) on 30 mm Honeycomb Insulation System	60	63	56	3

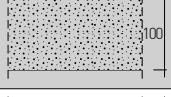
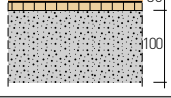
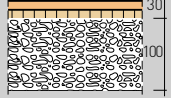
System drawing	Construction	Constr. height	Sound insulation Impact $L_{n,w}$	Airborne R_w	Area of application
		mm	dB	dB	
	2 E 22 (2 x 12,5 mm Gypsum Fibreboards) on 40 mm Steico Isorel	65	68	53	2
	2 E 31 (2 x 10 mm Gypsum Fibreboards + 10 mm Wood Fibre) with 40 mm Bonded Levelling Compound	70	70	49	3
	2 E 22 (2 x 12,5 mm Gypsum Fibreboards) on 30 mm EPS Underfloor Heating on 10 mm fermacell on 20 mm Floorrock GP	85	66	52	1
	2 E 22 (2 x 12,5 mm Gypsum Fibreboards) on 60 mm Levelling Compound	85	68	54	3
	2 E 31 (2 x 10 mm Gypsum Fibreboards + 10 mm Wood Fibre) on 60 mm Levelling Compound	90	67	54	3
	2 E 31 (2 x 10 mm Gypsum Fibreboards + 10 mm Wood Fibre) on 60 mm Honeycomb Insulation System	90	61	59	3
	2 E 22 (2 x 12,5 mm Gypsum Fibreboards) on 20 mm Steico Therm on 60 mm Honeycomb Insulation System	105	62	60	1
	2 E 22 (2 x 12,5 mm Gypsum Fibreboards) on 100 mm Bonded Levelling Compound	125	68	52	3
	2 E 31 (2 x 10 mm Gypsum Fibreboards + 10 mm Wood Fibre) on 100 mm Bonded Levelling Compound	130	67	52	3
	2 E 31 (2 x 10 mm Gypsum Fibreboards + 10 mm Wood Fibre) on 100 mm Levelling Compound	130	64	51	1



Base floor

$R_w = 55 \text{ dB}$

$L_{n,w} = 62 \text{ dB}$

Closed wooden timber joist floor, de-coupled suspended ceiling

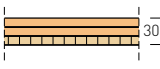
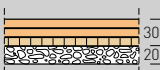
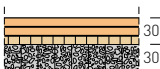
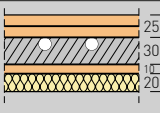
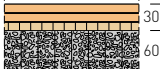
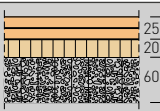
System drawing	Construction	Constr. height	Sound insulation Impact $L_{n,w}$	Airborne R_w	Area of application
		mm	dB	dB	
	2 E 31 (2 x 10 mm Gypsum Fibreboards + 10 mm Wood Fibre)	30	53	63	3
	2 E 31 (2 x 10 mm Gypsum Fibreboards + 10 mm Wood Fibre) with 20 mm Levelling Compound	50	50	65	3
	2 E 31 (2 x 10 mm Gypsum Fibreboards + 10 mm Wood Fibre) on 30 mm Honeycomb Insulation System	60	42	73	3
	2 E 22 (2 x 12,5 mm Gypsum Fibreboards) on 30 mm EPS Underfloor Heating on 10 mm fermacell on 20 mm Floorrock GP	85	50	66	1
	2 E 31 (2 x 10 mm Gypsum Fibreboards + 10 mm Wood Fibre) on 60 mm Honeycomb Insulation System	90	39	77	3
	2 E 22 (2 x 12,5 mm Gypsum Fibreboards) on 20 mm Steico Therm on 60 mm Honeycomb Insulation System	105	39	78	1



Base floor

R_w 55 dB

$L_{n,w}$ 78 dB

Solid floor

System drawing	Construction	Constr. height	Sound insulation Impact sound improvement ΔL_w , for solid floor according to EN 12354	Area of application
		mm	dB	
	2 E 31 (2 x 10 mm Gypsum Fibreboards + 10 mm Wood Fibre)	30	21 R_w = 61 dB	3
	2 E 11 (2 x 10 mm Gypsum Fibreboards) on 20 mm Levelling Compound	40	18	2
	2 E 22 (2 x 12,5 mm Gypsum Fibreboards) on 17/16 mm Wood Fibre Pavatex Pavapor	41	22	1
	2 E 22 (2 x 12,5 mm Gypsum Fibreboards) with 20 mm Levelling Compound	45	20	3
	2 E 31 (2 x 10 mm Gypsum Fibreboards + 10 mm Wood Fibre) on 20 mm Levelling Compound	50	24	3
	2 E 32 (2 x 10 mm Gypsum Fibreboards + 10 mm Mineral Wool) on 20 mm Levelling Compound	50	29	1
	2 E 22 (2 x 12,5 mm Gypsum Fibreboards) with 30 mm EPS Underfloor Heating	55	20 R_w = 59 dB	1

System drawing	Construction	Constr. height	Sound insulation Impact sound improvement ΔL_w for solid floor according to EN 12354	Area of application
		mm	dB	
	2 E 22 (2 x 12,5 mm Gypsum Fibreboards) on 40 mm Wood Fibre Steico Isorel	65	26	2
	2 E 22 (2 x 12,5 mm Gypsum Fibreboards) on 40 mm Bonded Levelling Compound	65	22	3
	2 E 22 (2 x 12,5 mm Gypsum Fibreboards) on 22/21 mm Wood Fibre Pavatex Pavapor on 20 mm Levelling Compound	66	27	1
	2 E 31 (2 x 10 mm Gypsum Fibreboards + 10 mm Wood Fibre) on 40 mm Bonded Levelling Compound	70	24	3
	2 E 22 (2 x 12,5 mm Gypsum Fibreboards) on 60 mm Levelling Compound	85	22	3
	2 E 31 (2 x 10 mm Gypsum Fibreboards + 10 mm Wood Fibre) on 60 mm Levelling Compound	90	25	3
	2 E 32 (2 x 10 mm Gypsum Fibreboards + 10 mm Mineral Wool) on 60 mm Levelling Compound	90	31	1
	2 E 31 (2 x 10 mm Gypsum Fibreboards + 10 mm Wood Fibre) on 100 mm Bonded Levelling Compound	130	25	3

Kiwa Nederland B.V.,

Dr. Wessel Churchillaan 273
 NL-2286 EA Rijswijk
 Postbus 70
 NL- 2280 AB Rijswijk
 Tel.: +31-(0)70-414 44 00
 Fax: +31-(0)70-414 44 20
 E-mail: gdnl@kiwa.nl



Lid van EOTA
 Member of EOTA

European Technical Approval**ETA 03/0006****Trade name**

Insulating dry floor finishing systems with FERMACELL flooring elements

Holder of the approval

Fermacell GmbH
 Dammstraße 25
 D-47119 Duisburg
 Germany

Internet www.fermacell.de

Generic type and use of construction product

The insulating dry floor finishing systems with FERMACELL flooring elements are intended for use in new build and existing (refurbishment) houses and other buildings for raising the height of floors or leveling out uneven floors. They can only be used on structural floors which provide overall support to the flooring elements. The floor finishing systems are not intended to be used without a floor covering.

Validity from to

2013-06-01
 2018-06-01

Manufacturing plant

Plant 1, Plant 2, Plant 3

Report number

Kiwa K25203/03

This European Technical Approval contains

21 pages



Europese Organisatie voor Technische Goedkeuringen
 European Organisation for Technical Approvals
 Europäische Organisation für Technische Zulassungen
 Organisation pour l'Agrément Technique Européen

9.4 Testing and approval documents

There are a number of test certificates, approval documents, reports and comparative documents for constructions with **fermacell** Flooring Elements.

fermacell also has a European Technical Approval ETA (CE 04 ETA - 03-0006), all **fermacell** Flooring Elements are CE certified.

fermacell Gypsum Fibreboards are classified as non-combustible, class A2-s1 d0 in acc. with EN 13501-1.

The fire protection classification of **fermacell** Flooring Elements in conjunction with various base floors for fire resistance classes F 30 to F 120 we undertaken as per certificate P-3981/9177 by the official Materials Testing Institute for Building, Braunschweig.

10 Material requirements

10.1 Material usage tables

Material usage for fermacell Flooring Elements per m ² installation area:	
fermacell Flooring Elements	approx. 1.33 elements
fermacell Floor Glue	approx. 40 – 50 g
fermacell Floor Screws	approx. 15 No
Special Diverging Staples (Alternative) Length 18-19 mm; wire diameter ≤ 1.5 mm	approx. 19 No
fermacell Joint Filler	approx. 0.1 kg
fermacell Self-Levelling Compound	approx. 1.4 kg/mm layer thickness
fermacell Levelling Compound	approx. 10 l/cm depth of packing
fermacell Bonded Levelling Compound	approx. 10 l/cm depth of packing
fermacell Honeycomb System	approx. 0.67 elements
fermacell Honeycomb Infill (30 mm)	approx. 2 bags
fermacell Honeycomb Infill (60 mm)	approx. 4 bags

Note

The floor screws must not penetrate through to the insulation or touch, rest on or bind with the substrate, as **fermacell** Flooring Elements are a floating floor system.

Material usage for fermacell Gypsum Fibreboards per m ² for installation of a 3 rd layer:	
fermacell Gypsum Fibreboard 1000 x 1500 mm	approx. 0.66 boards
fermacell Floor Glue	approx. 130 – 150 g
fermacell Floor Screws 3.9 x 22 mm	approx. 25 No
Special diverging staples (Alternative) Length 21–22 mm; wire diameter ≤ 1.5 mm	approx. 25 No

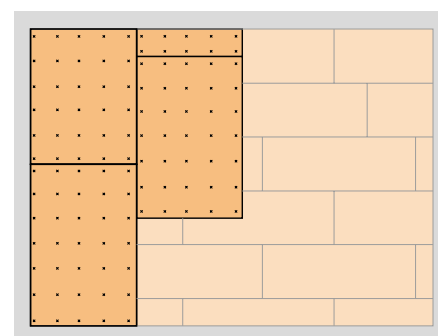

Installation Detail – 3rd layer
10 mm **fermacell** Gypsum Fibreboard
onto **fermacell** Flooring Elements

Material usage fermacell Powerpanel H ₂ O Flooring Element per m ² installation area:	
fermacell Powerpanel H ₂ O Flooring Element	1.6 elements
fermacell Floor Glue	approx. 40 – 50 g
fermacell Powerpanel H ₂ O Flooring Element Floor Screws	20 No
fermacell Powerpanel Surface Finish	1.2 kg/mm layer thickness





Material fixings and jointing materials usage by type of fermacell Flooring Element		
fermacell Flooring Element	Screws	Alternative: Special diverging staples (see also staple list Page 61)
fermacell Flooring Element 2 E 11 (2 x 10 mm) laid directly over a firm substrate, as a floating installation	fermacell Floor Screws 3.9 x 19 mm usage: ~ 15 No/m ² Screw spacing: ≤ 200 mm	Alternative: Special diverging staples 18-19 mm usage: ~ 19 No/m ² Staple spacing: ≤ 150 mm
fermacell Flooring Element 2 E 11 (2 x 10 mm) laid over insulation material as a floating installation	fermacell Screws 3.9 x 22 mm usage: ~ 15 No/m ² Screw spacing: ≤ 200 mm	Alternative: Special diverging staples 18-19 mm usage: ~ 19 No/m ² Staple spacing: ≤ 150 mm
fermacell Flooring Element 2 E 31 (2 x 10 mm + 10 mm wood fibre)	fermacell Screws 3.9 x 22 mm usage: ~ 15 No/m ² Screw spacing: ≤ 200 mm	Alternative: Special diverging staples 18-19 mm usage: ~ 19 No/m ² Staple spacing: ≤ 150 mm
fermacell Flooring Element 2 E 22 (2 x 12,5 mm)	fermacell Screws 3.9 x 22 mm usage: ~ 15 No/m ² Screw spacing: ≤ 200 mm	Alternative: Special diverging staples 21-22 mm usage: ~ 19 No/m ² Staple spacing: ≤ 150 mm
fermacell Flooring Element 2 E 33 (2 x 12,5 mm + 10 mm wood fibre)	fermacell Screws 3.9 x 22 mm usage: ~ 15 No/m ² Screw spacing: ≤ 200 mm	Alternative: Special diverging staples 21-22 mm usage: ~ 19 No/m ² Staple spacing: ≤ 150 mm
fermacell Powerpanel H ₂ O Flooring Element (2 x 12,5 mm Powerpanel board)	Powerpanel H ₂ O Floor Screws 3.5 x 23 mm usage: ~ 20 No/m ² Screw spacing: ≤ 150 mm	Alternative: Special diverging staples 21-22 mm usage: ~ 20 No/m ² Staple spacing: ≤ 150 mm

Manufacturers of special diverging staples				
	fermacell Flooring Elements 2 E 11, 2 E 31, 2 E 16 (top layer 2 x 10 mm)		fermacell Flooring Elements 2 E 22, 2 E 33, Powerpanel H ₂ O Flooring Element (top layer 2x12,5 mm)	
	Length: 18–19 mm	Gauge: ≥ 1,5 mm	Length: 21–22 mm	Gauge: ≥ 1,5 mm
	Fixing spacing ≤ 150 mm			
No.	Manufacturer	Staple type designation by respective manufacturer		
1	Schneider/Atro	114/18 CDNK HZ		114/22 CDNK HZ
2	BeA	155/18 NK HZ CD		155/21 NK HZ CD
3	Bostitch	BCS 4 19 CD		BCS 4 22 CD
4	Haubold	KG 718 CDnk		KG 722 CDnk
5	Holz-Her	G19 GALV/F		G22 GALV/F
6	Paslode	S 16 3/4" CD		S 16 7/8" CD
7	Poppers Senco	N 11 LAB		N 12 LAB
8	Prebena	Z 19 CDNK HA		Z 22 CDNK HA
9	YoungBlack	G5562		18GC-DC

Refer to Manufacturer's for their latest product references and information

Further information can
be obtained from the
fermacell Technical help
line **0121 311 3480**

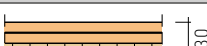
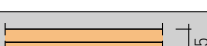
10.2 Installation times

fermacell Flooring Elements			
Type	fermacell construction	Short description	Installation time* min/m ²
2 E 11		2 x 10 mm fermacell	10 to 14
2 E 22		2 x 12,5 mm fermacell	10 to 14
2 E 31		2 x 10 mm fermacell 10 mm Wood Fibre-insulation board	10 to 14
2 E 33		2 x 12,5 mm fermacell 10 mm Wood Fibre-insulation board	10 to 14
2 E 11 – 2 E 33		Additional third layer fermacell	7 to 10
Powerpanel H ₂ O Flooring Element		25 mm fermacell Powerpanel H ₂ O Flooring Element	11 to 15
2 E 11 – 2 E 33, H ₂ O Flooring Element		Additional fermacell Flooring Elements (screws instead of staples)	2
2 E 11 – 2 E 33		Additional fermacell Self-Levelling Compound (mix and apply)	10
2 E 11 – 2 E 33, H ₂ O Flooring Element		Additional fermacell Levelling Compound ≤ 10 mm to 50 mm Additional fermacell Levelling Compound > 50 mm to 100 mm	10 to 15 15 to 20
2 E 11 – 2 E 33, H ₂ O Flooring Element		Additional kraft paper or polyethylene sheeting as trickle protection	2 to 3
2 E 11 – 2 E 33, H ₂ O Flooring Element		Additional insulation under flooring elements	2 to 4
2 E 11 – 2 E 33, H ₂ O Flooring Element		Additional fermacell Honeycomb Infill 30 mm Additional fermacell Honeycomb Infill 60 mm (with compaction)	7 to 10 12 to 15
2 E 11 – 2 E 33, H ₂ O Flooring Element		Additional fermacell Bonded Levelling Compound (100 mm mix and apply)	15 to 18 ¹⁾ 20 to 23 ²⁾
2 E 11 – 2 E 33, H ₂ O Flooring Element		Additional perimeter strips	1 min/lfdm

¹⁾ with a mechanical screed pump or special mixer ²⁾ with portable mixer.

* depending on room layout and installation conditions.

Fermacell
7 The Priory
Old London Road
Canwell
Sutton Coldfield
B75 5SH
Telephone: 0121 311 3480
Fax: 0121 311 1882
E-Mail: fermacellorders-uk@xella.com

All information and data is correct at the time of going to print. We reserve the right to make technical changes at any time.

www.fermacell.co.uk

fermacell[®]

A European business

The fermacell product range is today manufactured in 4 factories, 3 in Germany and 1 in the Netherlands. Continually increasing demand has led to the decision to open an additional factory in northern Spain (June 2013).

With sales operations across Europe and one in the Middle East, fermacell products are used in construction projects from Aberdeen to Sicily and from Madrid to Warsaw. UK and international case studies demonstrate that construction industry professionals across Europe understand and value fermacell as the "ultimate building board".

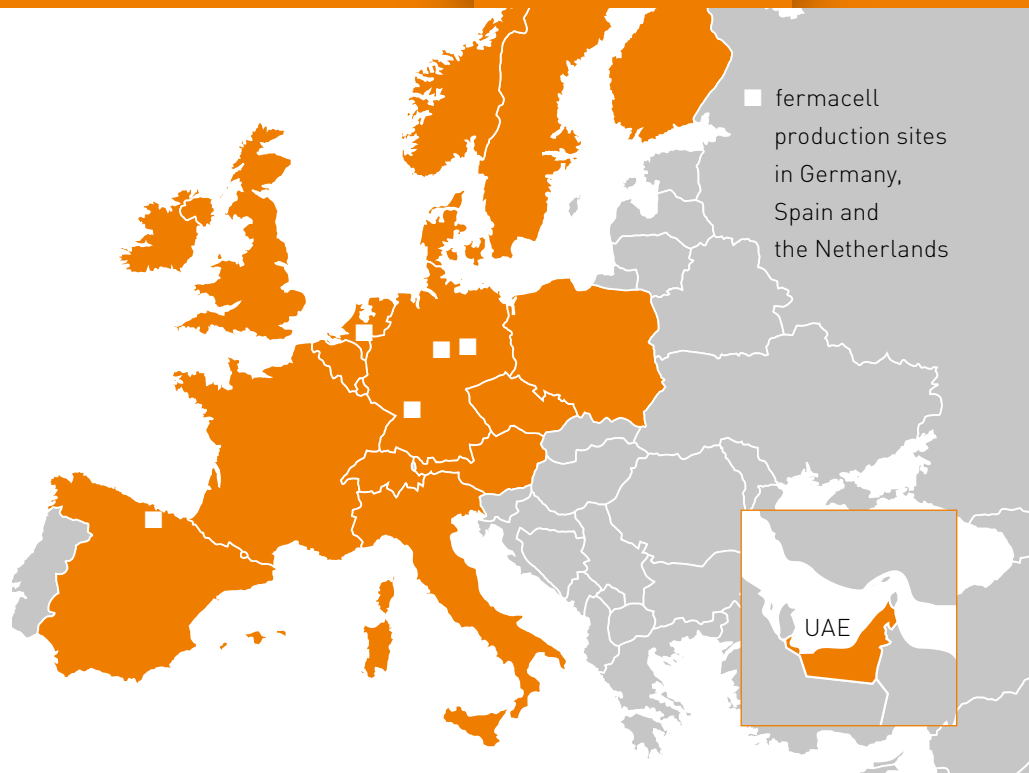

Orejo Factory, Spain



Calbe Factory, Germany



Wijchen Factory, the Netherlands